

C | D | A

*Built for your life*



Appliances • Sinks • Taps

April 2017





## ISO9001 accredited



FS 532687

CDA have achieved ISO9001 accreditation, recognising our commitment to continuous improvement.

## Why choose CDA?

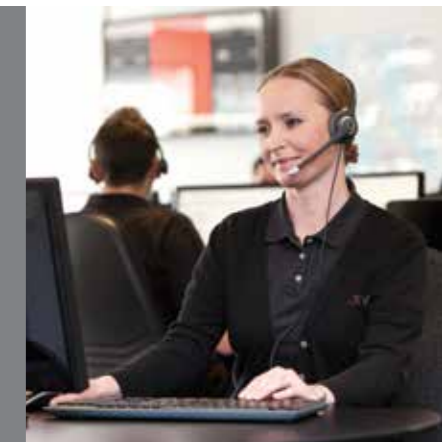

### Our assurance of quality

Our on-site testing laboratory ensures that only safe, reliable products are brought to market. We test to the British consumers' exacting standards without compromise.

### Dedicated engineers

We use our own dedicated service engineers, equipped with a large range of CDA spare parts allowing them to achieve an excellent first time fix rate.

### In-house Customer Care Department

Our in-house Customer Care Department, based at our head office in Nottinghamshire, is made up of highly knowledgeable and experienced staff who will support you throughout the lifetime of your product.

### Over 25 years experience

Established for over 25 years, CDA have built a reputation for stylish, innovative and award winning products that consistently deliver outstanding results.

### More deliveries to you

CDA delivers to retailers & kitchen studios daily so your new appliances will arrive quickly. All of our stock is held between our 9 acre site in Nottinghamshire and an additional warehouse in Newton. These central locations are ideally located to ensure efficient and fast distribution across the UK.

### Part of the Amica group PLC

In December 2015, CDA became part of the Amica Group.

Amica, a kitchen appliance manufacturer based in Poland, operate in 50 countries worldwide and have over 70 years' experience in the industry.

CDA share the same vision of providing the best products possible, as well as our values of good environmental practice, and together we will deliver even more for customers.



## Our guarantee

All CDA appliances are covered by a 5 year parts and 2 year labour guarantee for complete peace of mind.



# Contents

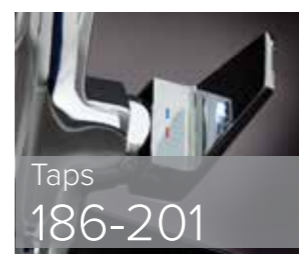
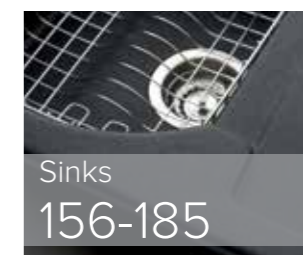
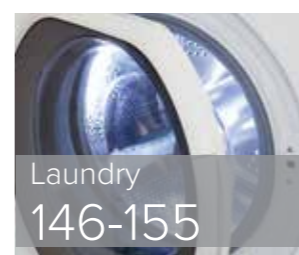
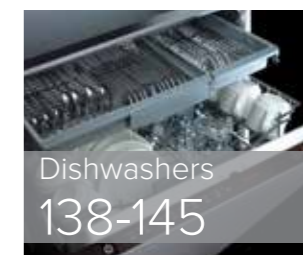
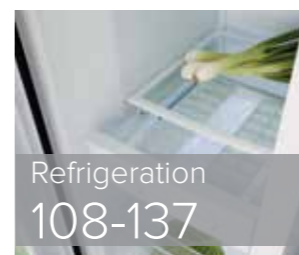
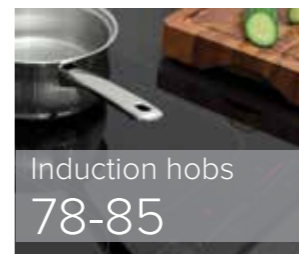
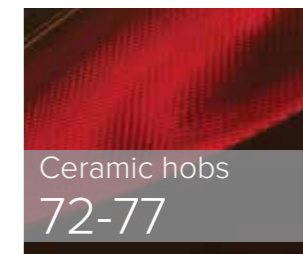
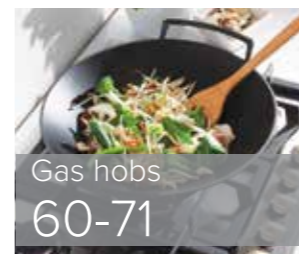
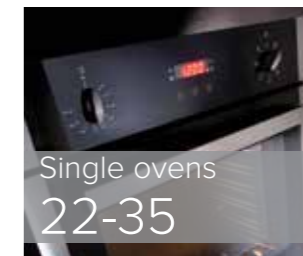

“Quality is something we respect and strive for in our products, our people and our service. Our reputation is built on delivering genuine quality through those three foundations every single day.”

Ian Kershaw  
CDA founder and Chairman

# Oven functions explained



## Oven light

This illuminates the oven cavity for easy viewing of food during cooking.



## Defrost

Using the fan only, this oven function circulates the air around the oven cavity, speeding up the natural defrosting process.



## Conventional oven

This function uses the top and bottom heating elements only. Natural convection creates a perfect cooking zone in the centre of the oven, ideal for dark fruit cakes and pastries.



## Fan-assisted oven

Using the fan to circulate the heat produced by the top and bottom heating elements, this function distributes the heat around the oven to give an even temperature throughout.



## Fan oven

Using the circular heating element and the fan, this cooking function circulates heated air around the oven cavity; temperatures are achieved quickly reducing the need for preheating. Both cooking temperature and cooking time can be reduced for a more energy efficient cooking programme. This is perfect for cooking various food types simultaneously as foods are sealed quickly to prevent flavour transfer.



## Fan cooking with lower heat

Using the fan element to enhance the main heat being produced by the lower heating element, this function is perfect for cooking pizzas.



## Fan cooking with upper heat

Uses the fan element and the top element to create a gentle heat, ideal for reheating already cooked foods or keeping food warm.



## Fan with lower heat

The fan circulates the heat produced by the bottom heating element, ideal for one pot dishes such as casseroles or curries.



## Browning oven

The perfect finishing touch, using the top element only this function browns and crisps food with conventional heat. This is ideal for cauliflower or macaroni cheese.



## Warming oven

Using heat produced only by the bottom element, this natural heat is perfect for dough proving and blind baking.



## Clean function

Using the eco-clean programme setting, the oven will heat the cavity to around 250°C, loosening grease effectively avoiding the need for harsh oven cleaner chemicals and unnecessary hard work.



## Full grill/Half grill

This fully variable grill is ideal for grilling a full family meal.

Some ovens offer a half grill option, using just the centre section for grilling smaller quantities.



## Turbo grill

This fully variable grill reaches higher temperatures than a standard grill, ideal for finishing off a crème brulee topping for example.



## Fanned electric grill/ Half fanned electric grill

This uses the grill element and the fan to circulate the heat around the food.

Some ovens offer a half fanned grill option, using just the centre section for grilling smaller quantities.



## Rotisserie electric

Using the grill element, heat is radiated down on to food which is rotating on the rotisserie aiding even browning.



## Rotisserie fanned grill

For fast, even cooking, the fan circulates the grill heat around the food as it turns on the rotisserie, creating a perfect crispy finish.



## Rotisserie conventional

Using both the top and bottom elements ensures even cooking when using the rotisserie, ideal for pork, chicken and beef.



## Steam oven

Cooking with the power of steam alone locks more nutrients into your food. Steaming is the healthier option for cooking meat, fish, vegetables and fruits.



## Pyrolytic cleaning

This function raises the temperature of your oven to 450°C, reducing any food deposits to a fine ash which can then be easily wiped away from the oven interior.

Full pyrolytic clean - 2 hours.



## Gas oven

Heat rises from the gas burner at the base of the oven. This method of cooking (hot at the bottom, cooler at the top) is perfect for family meals, as foods can be cooked at different temperatures at the same time.



## Gas grill

This variable gas grill is used with the door ajar, giving you perfect results when grilling chops, burgers and sausages.



## Rotisserie gas

Our gas range cooker offers a rotisserie option, using either the grill or oven.



## Fanned gas oven

Heat rises from the gas burner at the base of the oven and is distributed by a fan, creating an even cooking temperature.



## Microwave function

Food is cooked from the outside in using microwaves, making this style of cooking quick and convenient.



## Microwave and grill

Food is cooked from the outside in using microwaves with the added feature of the grill browning the food.



## Microwave and fan oven

Food is cooked using microwaves and browned on the outside by the fan oven.



*All electric, all gas or the best of both with a professional style gas hob and multifunction electric ovens. There is a choice to suit every cook in any kitchen.*

# Range cookers

Our contemporary range cookers are designed to be beautiful in both form and function.



## Multi-function

Finished in black glass and stainless steel, our range cookers combine good looks with outstanding performance.

The 90cm and 100cm twin cavity dual fuel models boast a large main oven with 8 cooking functions, and a second oven with 4 or 5 functions.

Selected models also have a rotisserie and/or useful storage drawer.

## 90cm range cookers

Our collection of 90cm range cookers offers full gas or full electric professional twin oven models with a substantial main oven and a useful second oven, or a single large capacity oven.



## Useful accessories

Useful accessories such as plate warmer racks and space saver shelves make CDA range cookers the perfect choice for keen cooks.

The RV1200 range cooker is provided with an aluminium pastry plate, as shown below. Please see the accessory section for our full range of optional accessories.



# Quick guide to range cookers

Our collection of range cookers offers a wide variety of sizes and configurations:

- All gas, all electric or dual fuel models available.
- Sizes from 70cm to 120cm wide.
- One, two or three oven cavities.
- Five or six hob burners or zones, with an additional griddle plate hob available.

Our all gas range cooker has:

- Automatic ignition.
- Flame failure - a feature designed to close off the gas supply in the event that a burner is accidentally extinguished.
- LPG conversion kit included.



## 70cm wide



### RV701

- Dual fuel
- 5 burner gas hob
- Twin cavity oven, 2/4 functions
- Stainless steel

More details on p14

## 90cm wide



### RC9322

- All gas
- 6 burner gas hob
- Twin cavity oven, 3/5 functions
- Stainless steel

More details on p15



### RV911

- Dual fuel
- 5 burner gas hob
- Single cavity oven, 8 functions
- Stainless steel

More details on p16



### RV921

- Dual fuel
- 5 burner gas hob
- Twin cavity oven, 8/5 functions
- Stainless steel

More details on p17



### RV961

- All electric
- 5 zone ceramic hob
- Twin cavity oven, 8/5 functions
- Stainless steel

More details on p18

## 100cm wide



### RV1002

- Dual fuel
- 6 burner gas hob
- Twin cavity oven, 8/5 functions
- Stainless steel

More details on p19



### RV1061

- All electric
- 5 zone ceramic hob
- Twin cavity oven, 8/5 functions
- Stainless steel

More details on p20

## 120cm wide



### RV1200

- Dual fuel
- 5 burner gas hob and ceramic griddle
- Triple cavity ovens, 8/4/4 functions
- Stainless steel

More details on p21

**RV701** 70cm twin cavity range cooker, electric ovens, gas hob



Hob features

- 5 burners
- Wok burner
- Automatic ignition
- Cast iron pan supports
- Rear back guard
- Flame failure included

Oven features

- Easy clean enamel interior
- Cooling fan
- Interior halogen lights
- Chromed rack sides with integrated anti-tilt shelves
- Touch control programmable electronic clock/timer
- Double glazed door with removable inner door glass for easy cleaning
- Removable doors
- Main oven - side opening door
- Second oven - drop down door

Other features

- Adjustable feet

Accessories

- Cast iron wok support
- 2 flat shelves
- 1 space saver shelf
- 1 grill pan with grid
- 2 grill pan handles
- LPG conversion kit included

Optional accessories

- Griddle, RG1-E
- Telescopic shelf kit (main oven only), TSK1
- Catalytic liners (for main oven only), C5OL
- Catalytic liners (for second oven only), C6OL
- Pizza stone, ACG10
- Glass oven tray, ACG20

Available in

- Stainless steel

Hob specification

- Front left, auxiliary: 1kW
- Front right, rapid: 3kW
- Centre, wok: 3.5kW
- Rear left, semi-rapid: 1.75kW
- Rear right, semi-rapid: 1.75kW

Technical specification

- Main oven useable capacity: 53L net
- Second oven useable capacity: 35L net
- Rated gas input: 11kW
- Rated electrical power: 4.28kW
- Power supply required: 20A

Energy efficiency rating

- Energy rating (main oven): A
- Energy rating (Second oven): A

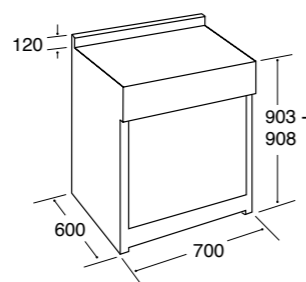

**RC9322** 90cm twin cavity range cooker, gas ovens, gas hob



Hob features

- 6 burners
- Wok burner
- Automatic ignition
- Cast iron pan supports
- Rear back guard
- Flame failure included

Oven features

- Easy clean enamel interior
- Cooling fan
- Interior halogen lights
- Chromed rack sides with integrated anti-tilt shelves
- Minute minder
- Double glazed doors with removable inner door glass for easy cleaning
- Second oven:
  - rotisserie can operate with either grill or oven functions

Other features

- Adjustable feet
- Storage compartment

Accessories

- Cast iron wok support
- Removable heat deflectors
- 2 + 1 flat shelves
- 2 grill pans with grids
- 2 grill pan handles
- 1 rotisserie kit
- LPG conversion kit included

Optional accessories

- Griddle, RG1-E
- Catalytic liners (for main oven only), C3OL
- Pizza stone, ACG10

Available in

- Stainless steel

Hob specification

- Front left, wok: 3.5kW
- Front centre, auxiliary: 1kW
- Front right, auxiliary: 1kW
- Rear left, semi-rapid: 1.75kW
- Rear centre, rapid: 3kW
- Rear right, semi-rapid: 1.75kW

Technical specification

- Main oven useable capacity: 67L net
- Second oven useable capacity: 41L net
- Rated gas input: 17.9kW
- Rated electrical power: 100W
- Power supply required: 3A

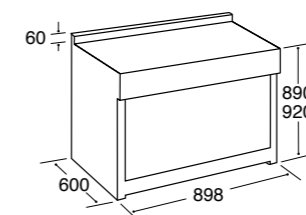



**RV911** 90cm single cavity range cooker, electric oven, gas hob



Hob features

- 5 burners
- Wok burner
- Automatic ignition
- Cast iron pan supports
- Flame failure included

Oven features

- Easy clean enamel interior
- Cooling fan
- Interior halogen lights
- Chromed rack sides with integrated anti-tilt shelves
- Touch control programmable electronic clock/timer
- Triple glazed door with removable inner door glass for easy cleaning
- Removable door

Other features

- Adjustable feet
- Storage compartment

Accessories

- Cast iron wok support
- 2 flat shelves
- 1 grill pan with grid
- LPG conversion kit included

Optional accessories

- Griddle, RG1-E
- Pizza stone, ACG10

Available in

- Stainless steel

Hob specification

- Front left, rapid: 3kW
- Front right, rapid: 3kW
- Centre, wok: 3.7kW
- Rear left, semi-rapid: 1.75kW
- Rear right, semi-rapid: 1.75kW

Technical specification

- Oven useable capacity: 103L net
- Rated gas input: 13.2kW
- Rated electrical power: 3.38kW
- Power supply required: 16A

Energy efficiency rating

- Energy rating: A

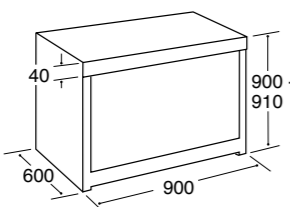

**RV921** 90cm twin cavity range cooker, electric ovens, gas hob



Hob features

- 5 burners
- Wok burner
- Automatic ignition
- Cast iron pan supports
- Flame failure included

Oven features

- Easy clean enamel interior
- Cooling fan
- Interior halogen lights
- Chromed rack sides with integrated anti-tilt shelves
- Touch control programmable electronic clock/timer
- Triple glazed doors with removable inner door glass for easy cleaning
- Removable doors

Other features

- Adjustable feet
- Storage compartment

Accessories

- Cast iron wok support
- 2 + 2 flat shelves
- 2 grill pans with grids
- LPG conversion kit included

Optional accessories

- Griddle, RG1-E
- Pizza stone, ACG10

Available in

- Stainless steel

Hob specification

- Front left, rapid: 3kW
- Front right, rapid: 3kW
- Centre, wok: 3.7kW
- Rear left, semi-rapid: 1.75kW
- Rear right, semi-rapid: 1.75kW

Technical specification

- Main oven useable capacity: 63L net
- Second oven useable capacity: 32L net
- Rated gas input: 13.2kW
- Rated electrical power: 4.35kW
- Power supply required: 20A

Energy efficiency rating

- Energy rating (main oven): A
- Energy rating (second oven): B

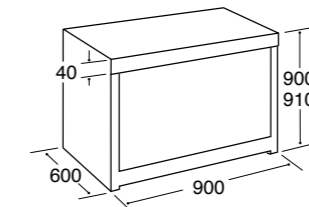



Two dual zone cooking areas make this ceramic hob totally flexible to meet your cooking needs.

**RV961** 90cm twin cavity range cooker, electric ovens, ceramic hob



- Hob features**
- 5 zones including 2 dual zones
  - Residual heat indicators

- Oven features**
- Easy clean enamel interior
  - Cooling fan
  - Interior halogen lights
  - Chromed rack sides with integrated anti-tilt shelves
  - Touch control programmable electronic clock/timer
  - Triple glazed door with removable inner door glass for easy cleaning
  - Removable doors

- Other features**
- Adjustable feet
  - Storage compartment

- Accessories**
- 2 + 2 flat shelves
  - 2 grill pans with grids

- Optional accessories**
- Pizza stone, ACG10

- Available in**
- Stainless steel

- Hob specification**
- Front left:
    - 140mm: 1.1kW
    - 210mm: 2kW
  - Front right, 140mm: 1.2kW
  - Rear left, 140mm: 1.2kW
  - Rear right, 180mm: 1.8kW
  - Centre, dual:
    - 140mm: 1.1kW
    - 250mm: 2kW
- Technical specification**
- Main oven useable capacity: 63L net
  - Second oven useable capacity: 32L net
  - Rated electrical power: 12.78kW
  - Power supply required: 45A
- Energy efficiency rating**
- Energy rating (main oven): A
  - Energy rating (second oven): B



The 63L capacity in the main oven allows plenty of room to cater for large roasting joints, plus all the trimmings. A second oven provides the flexibility to cook desserts and starters simultaneously.

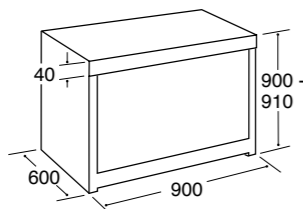

**RV1002** 100cm twin cavity range cooker, electric ovens, gas hob



- Hob features**
- 6 burners
  - Wok burner
  - Automatic ignition
  - Cast iron pan supports
  - Rear back guard
  - Flame failure included

- Oven features**
- Easy clean enamel interior
  - Cooling fan
  - Interior halogen lights
  - Chromed rack sides with integrated anti-tilt shelves
  - Touch control programmable electronic clock/timer
  - Double glazed door with removable inner door glass for easy cleaning
  - Removable doors

- Other features**
- Adjustable feet
  - Storage drawer

- Accessories**
- Cast iron wok support
  - 2 space saver shelves
  - 2 grill pans with grids
  - 2 grill pan handles
  - 1 rotisserie kit
  - Plate warmer rack/shelf for second oven
  - LPG conversion kit included

- Optional accessories**
- Griddle, RG1-E
  - Catalytic liners (for main oven only), C3OL
  - Pizza stone, ACG10
  - Glass oven tray, ACG20

- Available in**
- Stainless steel
- Hob specification**
- Front left, triple-ring/wok: 3.5kW
  - Front centre, auxiliary: 1kW
  - Front right, triple-ring/wok: 3.5kW
  - Rear left, semi-rapid: 1.75kW
  - Rear centre, rapid: 3kW
  - Rear right, semi-rapid: 1.75kW
- Technical specification**
- Main oven useable capacity: 70L net
  - Second oven useable capacity: 45L net
  - Rated gas input: 14.5kW
  - Rated electrical power: 3.79kW
  - Power supply required: 20A
- Energy efficiency rating**
- Energy rating (main oven): B
  - Energy rating (second oven): B

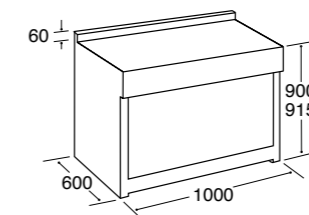



The RV1200 offers maximum cooking space and ultimate flexibility with a choice of three ovens, a ceramic griddle, five gas burners and a storage drawer.

**RV1061** 100cm twin cavity range cooker, electric ovens, ceramic hob



- Hob features**
- 12 power levels on dual zones
  - 6 power levels on single zones
  - Rear back guard
  - Residual heat indicators

- Oven features**
- Easy clean enamel interior
  - Cooling fan
  - Interior halogen lights
  - Chromed rack sides with integrated anti-tilt shelves
  - Touch control programmable electronic clock/timer
  - Double glazed door with removable inner door glass for easy cleaning
  - Removable doors

- Other features**
- Adjustable feet
  - Storage drawer

- Accessories**
- 2 grill pans with grids
  - 2 grill pan handles
  - 2 space saver shelves
  - 1 plate warmer rack/shelf
  - 1 rotisserie kit

- Optional accessories**
- Pizza stone, ACG10
  - Catalytic liners (for main oven only), C3OL
  - Glass oven tray, ACG20

- Available in**
- Stainless steel
- Hob specification**
- Front left, 180mm: 1.7kW
  - Front right, 145mm: 1.2kW
  - Centre, dual:
    - 140mm: 1.1kW
    - 250mm: 2.0kW
  - Rear left, 145mm: 1.2kW
  - Rear right, dual:
    - 120mm: 0.75kW
    - 210mm: 2.2kW
- Technical specification**
- Main oven useable capacity: 70L net
  - Second oven useable capacity: 45L net
  - Rated electrical power: 12.1kW
  - Power supply required: 45A
- Energy efficiency rating**
- Energy rating (main oven): B
  - Energy rating (second oven): B

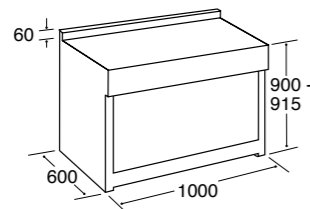

**RV1200** 120cm triple cavity range cooker, electric ovens, gas hob and ceramic griddle



- Hob features**
- 5 gas burners and one ceramic griddle zone
  - 12 power levels on griddle zone
  - Wok burner
  - Automatic ignition
  - Cast iron pan supports
  - Rear back guard
  - Flame failure included

- Oven features**
- Easy clean enamel interior
  - Cooling fan
  - Interior halogen lights
  - Chromed rack sides with integrated anti-tilt shelves
  - Touch control programmable electronic clock/timer
  - Double glazed door with removable inner door glass for easy cleaning
  - Removable doors

- Other features**
- Adjustable feet
  - Storage drawer

- Accessories**
- Cast iron wok support
  - 2 flat shelves
  - 2 space saver shelves
  - 2 grill pans with grid
  - 2 grill pan handles
  - 1 aluminium pastry plate
  - LPG conversion kit included

- Optional accessories**
- Griddle, RG1-E
  - Catalytic liners (main and second ovens), C5OL
  - Pizza stone, ACG10
  - Glass oven tray, ACG20

- Available in**
- Stainless steel

- Hob specification**
- Front left, triple-ring/wok: 3.5kW
  - Front right, triple-ring/wok: 3.5kW
  - Centre left gas, dual: 4.5kW
  - Centre right, ceramic griddle: 1.3kW
  - Rear left, semi-rapid: 1.75kW
  - Rear right, semi-rapid: 1.75kW

- Technical specification**
- Top left oven useable capacity: 37L net
  - Lower left oven useable capacity: 59L net
  - Top right oven useable capacity: 59L net
  - Rated gas input: 15kW
  - Rated electrical power: 7.9kW
  - Power supply required: 32A

- Energy efficiency rating**
- Energy rating (main oven): A
  - Energy rating (second oven): A
  - Energy rating (third oven): A

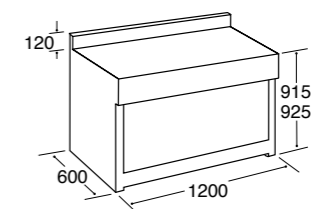

*We understand that your oven needs to do more than just cook food well. That's why we've combined stunning new designs with the best cooking performance possible. With our wide range of ovens, including pyrolytic, touch control and gas models, you are guaranteed to find the perfect oven for your home.*



# Single ovens

Our expertise in appliance manufacture means that whichever of our many stylish models you choose, you can be certain of high performance, advanced technology and, of course, reliability.



## Stylish aesthetics

Our range of single ovens offers considered design features that will complete your kitchen perfectly. From ergonomically designed control knobs to brushed steel finish door handles and side strips, whichever model you choose, you can be sure that every detail has been deliberated to bring you the best in function and style.

## Large capacity ovens

CDA's range of single ovens, SK110, SK210, SK310 and SK410, features an extra-large cavity with a gross capacity of 80L. In real terms, this extra usable cooking space, plus additional shelf positions, will allow you to achieve better cooking results with more food in the oven at the same time.

The range features an energy rating of A and built in safety features, such as anti-tilt shelving to reduce accidents removing hot food from the oven, as standard.

With extra shelf positions available on the SK110, SK210, SK310 and SK410 oven models, up to 6 trays of cookies may be baked at once. This extra space means that you will also have no problem roasting a joint of meat, potatoes and vegetables together for a special family meal.



Extra large cavity

Cutting edge style,  
performance and reliability



#### Self-cleaning

Spend less time on chores by choosing a pyrolytic oven. The self-cleaning programme will allow you to get on with other things whilst your oven 'cleans itself'. The programme works by automatically locking the door, for your family's safety, and heating the internal oven cavity to over 450°C to incinerate residual cooking fat or spills to a fine ash. All you need to do is simply wipe the small amount of ash from the bottom of your oven away after the cycle has finished. What's more, running a pyrolytic programme costs around 45p; much cheaper than branded oven cleaners.

#### Easy clean enamel interior

Our ovens have a smooth, easy clean enamel interior. By using the highest grades of enamel during production, the oven walls are less porous and therefore much less susceptible to absorbing grease and residue from food whilst cooking; this results in an easy to maintain oven with effortless cleaning.



#### Cool door with removable glass

Our single and double oven range comes with removable door glass for easy cleaning and maintenance. With double glazed doors as standard the range also includes triple and quadruple glazed models, these are cool to the touch even whilst cooking at high temperatures.



Offset lateral  
halogen lights

#### Offset lateral halogen lights

The halogen lighting inside the SK310 and SK410 models provides clear illumination whilst cooking, allowing you to easily check the progress of your meal. By removing the need to open the oven door during cooking, an even temperature can be maintained to produce perfect results every time.

*Our touch control models, the SK410, SK510, VC801, VK702 and VK902, have discrete icons that are illuminated and clearly visible when in use but barely noticeable when not, leaving an uninterrupted clean line across your integrated CDA appliances.*



Design, innovation and passion are at the heart of everything that we do. Our products are manufactured using the highest quality materials to form the centrepiece of your kitchen.

# Quick guide to single ovens

CDA offer a choice of designs and features to meet a broad range of tastes.

*Products with this icon have a huge 80L gross capacity, providing plenty of room to cook for the whole family.*



### SG120

- 5 function gas oven
  - Capacity: 54L net
  - Available in stainless steel or white
- More details on p28



### SC620

- 7 functions
  - Reversible side opening
  - Capacity: 59L net
- More details on p28



### SK110

- 4 functions
  - Capacity: 76L net
- More details on p29



### SK210

- 4 functions
  - Capacity: 76L net
- More details on p29



### SK310

- 7 functions
  - Capacity: 76L net
  - Available in stainless steel or black
- More details on p30



### SK410

- 10 functions
  - Full touch control
  - Capacity: 76L net
- More details on p31



### SK510

- 11 functions
  - Full touch control
  - Pyrolytic
  - Capacity: 59L net
  - Available in stainless steel or black
- More details on p32



### SK451

- 11 functions
  - Full touch control
  - Eco-clean
  - Capacity: 65L net
- More details on p33



### 6Q5

- 8 functions
  - Touch control programmer
  - Capacity: 53L net
- More details on p34



### SK381

- 8 functions
  - 90cm extra wide capacity
  - Capacity: 87L net
- More details on p35



## SG120 Five function gas oven



### Features

- 60 minute minder
- Easy clean enamel interior
- Interior light
- Cooling fan
- Chromed rack sides with integrated anti-tilt shelves
- Double glazed removable door with removable inner glass for easy cleaning
- Flame failure included

### Accessories

- 2 flat oven shelves
- 1 grill pan with grid
- LPG conversion kit included

### Optional accessories

- Pizza stone, ACG10
- Glass oven tray, ACG20

### Available in

- Stainless steel
- White

### Technical specification

- Rated gas input: 2.7kW
- Rated electrical power: 60W
- Power supply required: 3A
- Total useable capacity: 54L net

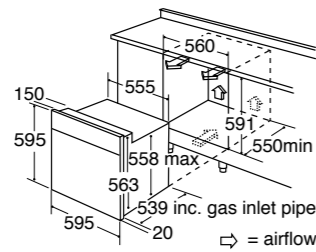

Stainless steel



White



## SC620 Seven function electric side opening multi-function oven



Supplied with a reversible magnetic close door

### Features

- Touch control programmable clock/timer
- Easy clean enamel interior
- Interior halogen light
- Cooling fan
- Chromed rack sides with integrated anti-tilt shelves
- Triple glazed removable cool door with removable inner glass for easy cleaning
- Reversible side opening door

### Accessories

- 2 flat oven shelves
- 1 grill pan with grid

### Optional accessories

- Pizza stone, ACG10
- Glass oven tray, ACG20

### Available in

- Stainless steel

### Technical specification

- Rated electrical power: 2kW
- Power supply required: 13A
- Total useable capacity: 59L net

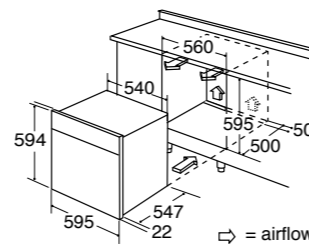

## SK110 Four function electric fan oven



### Features

- Easy clean enamel interior
- Interior halogen light
- Cooling fan
- Chromed rack sides with integrated anti-tilt shelves
- Double glazed removable door with removable inner glass for easy cleaning
- 6 shelf positions

### Accessories

- 2 flat oven shelves
- 1 grill pan with grid

### Optional accessories

- Telescopic shelf kit TSK3
- Pizza stone ACG10
- Glass oven tray ACG20

### Available in

- Stainless steel

### Technical information

- Rated electrical power: 2.16kW
- Power supply required: 13A
- Total useable capacity: 76L net

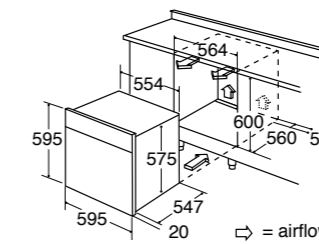

With a huge 80L gross capacity, the SK110, SK210, SK310 & SK410 models provide plenty of room to cook for the whole family.

## SK210 Four function electric fan oven



### Features

- Touch control programmable clock/timer
- Easy clean enamel interior
- Interior halogen light
- Cooling fan
- Chromed rack sides with integrated anti-tilt shelves
- Double glazed removable door with removable inner glass for easy cleaning
- 6 shelf positions

### Accessories

- 2 flat oven shelves
- 1 grill pan with grid

### Optional accessories

- Telescopic shelf kit TSK3
- Pizza stone ACG10
- Glass oven tray ACG20

### Available in

- Stainless steel

### Technical information

- Rated electrical power: 2.16kW
- Power supply required: 13A
- Total useable capacity: 76L net

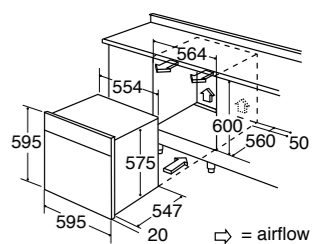

*Brushed stainless steel side strips add the perfect finishing touch to our single oven range, providing clean lines and framing the black glass design.*

**SK310** Seven function electric multi-function oven



Stainless steel

Black



Features

- Touch control programmable clock/timer
- Easy clean enamel interior
- Offset lateral halogen lights
- Cooling fan
- Chromed rack sides with integrated anti-tilt shelves
- Triple glazed removable cool door with removable inner glass for easy cleaning
- 6 shelf positions

Accessories

- 2 flat oven shelves
- 1 grill pan with grid

Optional accessories

- Telescopic shelf kit TSK3
- Pizza stone ACG10
- Glass oven tray ACG20

Available in

- Stainless steel
- Black

Technical information

- Rated electrical power: 2.16kW
- Power supply required: 13A
- Total useable capacity: 76L net

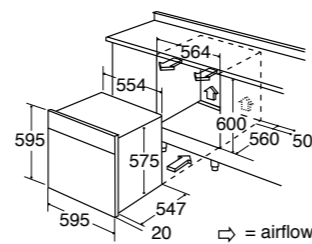

**SK410** Ten function electric multi-function LCD oven



Where you see products featuring 'offset lateral halogen lights' we have positioned lights on both sides of the oven cavity. This provides superb illumination across all the oven shelves.



Features

- Full touch control
- LCD display
- Easy clean enamel interior
- Offset lateral halogen lights
- Cooling fan
- Chromed rack sides with integrated anti-tilt shelves
- Triple glazed removable cool door with removable inner glass for easy cleaning
- Booster function for rapid preheat
- Safety key lock

- Memory function
- 6 shelf positions

Accessories

- 2 flat oven shelves
- 1 grill pan with grid

Optional accessories

- Telescopic shelf kit TSK3
- Pizza stone ACG10
- Glass oven tray ACG20

Available in

- Stainless steel

Technical information

- Rated electrical power: 3.1kW
- Power supply required: 13A
- Total useable capacity: 76L net

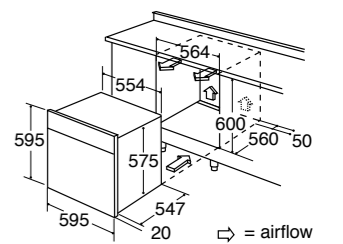



**Self-cleaning**  
 The SK510 has a handy pyrolytic 'self-cleaning' function. Be sure to remove your oven shelves before running the programme to avoid discolouration of the chrome under the high cleaning temperature.

**Top tip**  
 The SK451 comes with a useful temperature probe that will automatically turn off the oven once the preselected core temperature of the food has been reached; this is perfect for achieving your preference of roasted meat or poultry is cooked thoroughly.

**SK510** Eleven function LCD pyrolytic oven

**SK451** Eleven function electric multi-function oven



The SK510 pyrolytic oven is fitted with a quadruple glazed cool door for safety. The door will automatically lock during the programme to prevent accidentally opening the oven at such a high temperature giving peace of mind during the cleaning cycle.



Stainless steel

Black



Using the eco-clean programme, the SK451 will heat the cavity to around 250°C loosening grease effectively, avoiding the need for harsh oven cleaner chemicals and unnecessary hard work. Combining this non-invasive programme with the fitted catalytic liners, your oven will stay clean and use minimal energy in the process.



- Features**
- Full touch control
  - LCD display
  - Interior halogen light
  - Cooling fan
  - Safety lock for pyrolytic cleaning functions
  - Quadruple glazed removable cool door with removable inner glass for easy cleaning
  - Easy clean enamel interior
  - Chromed rack sides with integrated anti-tilt shelves

- Booster function for rapid preheat**
- Safety key lock
  - Memory function
- Accessories**
- 2 flat oven shelves
  - 1 grill pan with grid
- Optional accessories**
- Pizza stone ACG10
  - Glass oven tray ACG20

- Available in**
- Stainless steel
  - Black
- Technical specification**
- Rated electrical power: 3.1kW
  - Power supply required: 13A
  - Total useable capacity: 59L net

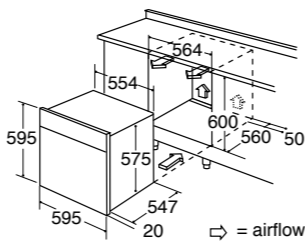

- Features**
- Full touch control
  - Easy clean enamel interior with catalytic liners
  - Offset lateral halogen lights
  - Cooling fan
  - Triple glazed removable cool door with removable inner glass for easy cleaning
  - Defrost function (40°C to 60°C)
  - Booster function for rapid preheat
  - Programmable recipe function
  - Eco-clean function
  - Safety key lock

- Accessories**
- Catalytic liners
  - 2 flat oven shelves
  - 1 grill pan with grid
  - Temperature probe

- Optional accessories**
- Catalytic liners, C12OL
  - Pizza stone, ACG10
  - Glass oven tray, ACG20

- Available in**
- Stainless steel

- Technical specification**
- Rated electrical power: 3.5kW
  - Power supply required: 16A
  - Total useable capacity: 65L net

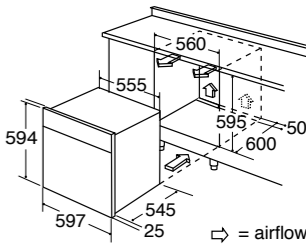

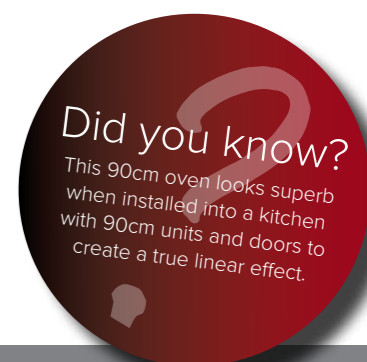

## 6Q5 Eight function electric Q-style multi-function oven



### Co-ordinating products

This oven matches the 4Q4 and 4Q5 hobs as well as the EVQ7 extractor.



#### Features

- Touch control programmable clock/timer
- Easy clean enamel interior
- Lateral halogen lights
- Cooling fan
- Chromed rack sides with integrated anti-tilt shelves
- Drop down grill
- Triple glazed removable cool door with removable inner glass for easy cleaning

#### Accessories

- 1 flat oven shelf
- 1 space saver oven shelf
- 1 glass oven tray
- 1 grill pan with grid
- 2 grill pan handles
- Telescopic shelf kit

#### Optional accessories

- Catalytic liners, C10OL
- Pizza stone, ACG10
- Glass oven tray, ACG20

#### Available in

- Stainless steel

#### Technical specification

- Rated electrical power: 2.35kW
- Power supply required: 13A
- Total useable capacity: 53L net

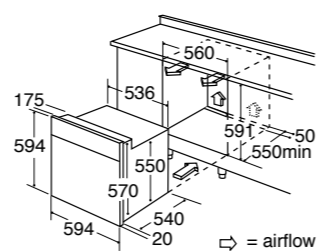

## SK381 90cm eight function electric multi-function oven



This 90cm wide oven provides a huge internal net capacity of 87L - ideal for entertaining or large families. Three chickens can cook side by side on one shelf.

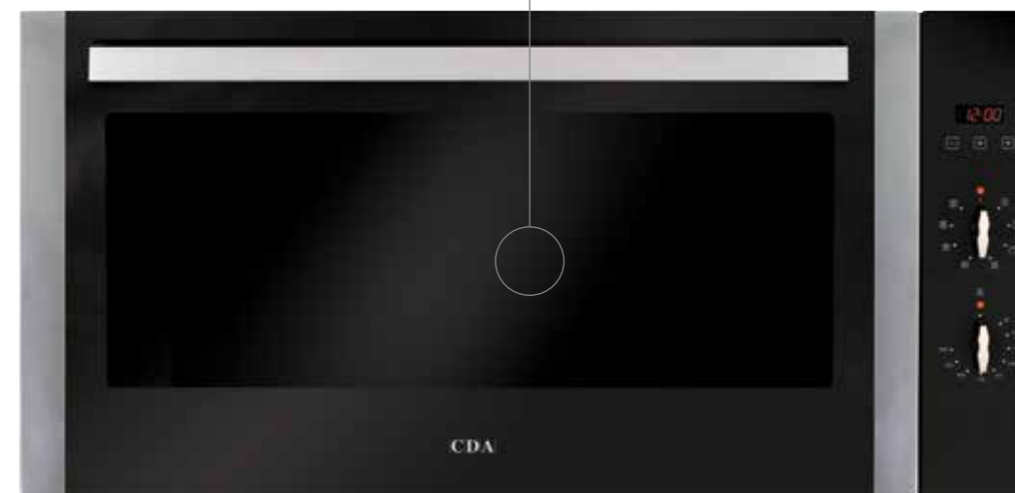

#### Features

- Touch control programmable clock/timer
- Extra large cavity
- Easy clean enamel interior
- Twin interior halogen lights
- Cooling fan
- Chromed rack sides with integrated anti-tilt shelves
- Double glazed removable door with removable inner glass for easy cleaning

#### Accessories

- 1 flat oven shelf
- 1 space saver oven shelf
- 1 grill pan with grid
- 2 grill pan handles

#### Optional accessories

- Catalytic liners (3 piece), C9OL
- Pizza stone, ACG10
- Glass oven tray, ACG20

#### Available in

- Stainless steel

#### Technical specification

- Rated electrical power: 3.05kW
- Power supply required: 16A
- Total useable capacity: 87L net

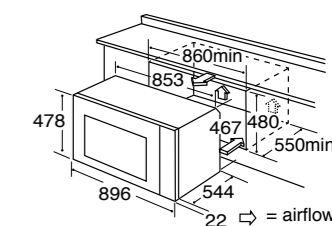



# Compacts

A range of useful and innovative appliances to add functionality and that special finishing touch to your kitchen.



*Build your personalised cooking space by combining any of our compact appliances. Choose from steam and grill, combination microwave grill, fan oven or warming drawers to suit your needs.*

## Steam cooking

Cooking with steam preserves flavour, vitamins and minerals. Our steam oven makes the process easy and has a refillable reservoir removing the need for connection to the mains water supply.



## Compact ovens

Our compact range offers a steam oven and a compact combination model. The VK902 provides a grill, microwave and a fan oven all in one neat space, making it the perfect choice for kitchens where space is limited.

## Drawers

A warming drawer is ideal for warming plates, proving bread, melting chocolate, making yoghurt or keeping dishes and cooked food warm. These are so useful that once you've had one you'll never want to do without! As well as warming drawers, we also offer an innovative grill drawer with regulated control and a 30 minute timer- perfect for healthier integrated cooking.



## Compact coffee maker

The VC801 automatic coffee maker will make mornings worth waking up for. This built-in 60cm coffee maker brings CDA's sleek styling into your kitchen design whilst offering superb features and functions. It comes with full touch control, multiple grind settings along with adjustable coffee strength and quantity for your perfect hot drink. You can use coffee beans or pre-ground coffee with this machine making it truly flexible to your lifestyle.

## Quick guide to compact cooking and microwaves

These versatile compact appliances look stunning when installed together as a bank. Install warming drawers beneath for ultimate cooking flexibility.

We have a choice of microwaves to suit your requirements - freestanding or built-in options are available.

## Compact refrigeration

Please see our refrigeration section for the following compact refrigeration products:

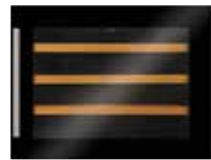

### FWV451

- Built-in compact wine cooler - See page 135.



### BVB4

- Built-in draught beer dispenser - See page 137.

## Microwaves



### VM100

- Freestanding microwave oven
  - LED timer and clock
  - Quick start
- More details on p46



### VM200

- Freestanding microwave oven and grill
  - LED timer and clock
  - Quick start
- More details on p46

## Microwaves



### VM130

- Built-in microwave oven
  - LED timer and clock
  - Quick start
  - Available in stainless steel or black
- More details on p47



### VM230

- Built-in microwave oven and grill
  - LED timer and clock
  - Quick start
  - Available in stainless steel or black
- More details on p47

## Compact appliances



### VK702

- Compact steam oven and grill
  - Full touch control
  - LED display
- More details on p40



### VK902

- Compact combination microwave, grill and fan oven
  - Full touch control
  - LED display
- More details on p40

## Drawers



### VW141

- Warming drawer
  - 6 place settings
  - Variable temperature
  - Smooth runners
  - Non-slip silicone mat
- More details on p43



### VW152

- Push-push warming drawer
  - 6 place settings
  - Variable temperature
  - Smooth runners
  - Non-slip silicone mat
- More details on p44

## Microwaves



### VM451

- Built-in microwave oven, grill and convection oven
  - LED timer and clock
  - Auto defrost
- More details on p48



### VM550

- Wall unit microwave oven
  - LED timer and clock
  - Auto defrost
- More details on p49

## Compact appliances



### VC801

- Compact coffee maker
  - 3 coffee strength settings
  - Touch control
- More details on p41

## Drawers



### VW281

- Large warming drawer
  - 12 place settings
  - Variable temperature
  - Smooth runners
  - Non-slip silicone mat
- More details on p45



### VW601

- Grill drawer
  - Regulated temperature control
  - Smooth runners
- More details on p42

## VK702 Compact steam oven and grill



### Features

- Full touch control
- LED display
- Interior lateral halogen light
- Stainless steel interior
- Variable temperature
- Variable grill
- Removable 1L water reservoir
- 8 auto-cook programmes
- Programmable clock/timer
- Double glazed removable door with removable inner door glass for easy cleaning
- Safety key lock

### Technical specification

- Total useable capacity: 32L net
- Rated electrical power: 3.1kW
- Power supply required: 13A

### Fitting note

- Should be installed as a built-in appliance.

### Accessories

- Stainless steel steam cooking set
- Trivet
- Wire shelf

### Available in

- Stainless steel

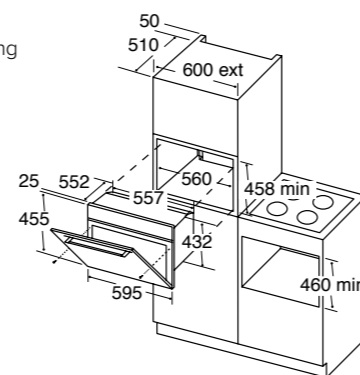

**Did you know?**

The steam function, used on a low temperature setting, is perfect for gentle defrosting.

## VK902 Compact combination microwave, grill and fan oven

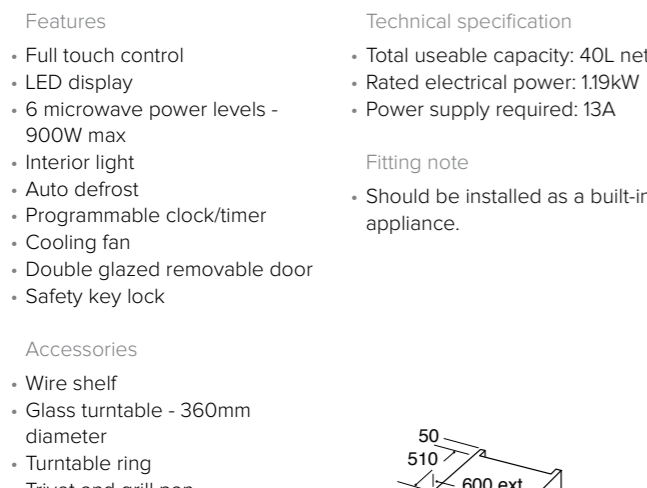

### Features

- Full touch control
- LED display
- 6 microwave power levels - 900W max
- Interior light
- Auto defrost
- Programmable clock/timer
- Cooling fan
- Double glazed removable door
- Safety key lock

### Technical specification

- Total useable capacity: 40L net
- Rated electrical power: 1.19kW
- Power supply required: 13A

### Fitting note

- Should be installed as a built-in appliance.

### Accessories

- Wire shelf
- Glass turntable - 360mm diameter
- Turntable ring
- Trivet and grill pan

### Available in

- Stainless steel

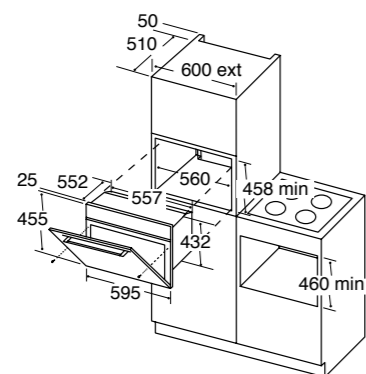

## VC801 Fully automatic coffee maker



### Features

- Fully automatic
- Full touch control
- Electronic programmer with LCD display
- 3 coffee strength settings
- Steam nozzle
- One or two cups
- Compatible with ground coffee and coffee beans
- Hot water and steam
- Integral water tank: 1.8L
- Integral coffee container: 0.2kg
- Low coffee warning
- Low water warning
- Removable drip tray
- Adjustable grind setting
- Integrated coffee grinder

### Available in

- Stainless steel

### Technical specification

- Rated electrical power: 1.35kW
- Power supply required: 13A
- Pump pressure: 15Bar



Adjustable coffee dispenser

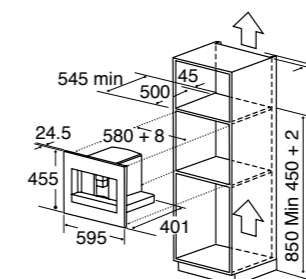

⇨ = airflow

Not only does the VC801 allow you to adjust coffee strength, cup size and grind settings to your taste, its 'bean to cup' single process grinds fresh coffee beans and dispenses perfect coffee in one motion to ensure maximum freshness.

## VW601 Grill drawer

### Features

- Cooling fan
- Temperature regulated control
- Variable grill
- Smooth, soft close runners
- Power indicator light
- 30 minute timer
- Removable drawer

### Available in

- Stainless steel

### Technical specification

- Rated electrical power: 1.83kW
- Power supply required: 13A

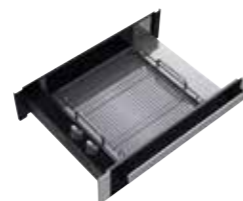

This versatile grill drawer is designed to be used beneath a compact cooking appliance.

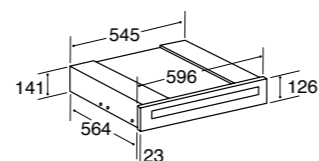

Removable grill tray

## VW141 Warming drawer

### Features

- Fan heat
- Temperature adjustable from 30°C to 80°C
- 6 place settings
- Smooth runners
- Non-slip silicone mat
- Power indicator light

### Available in

- Stainless steel

### Technical specification

- Rated electrical power: 432W max
- Power supply required: 3A
- Maximum capacity: 25kg

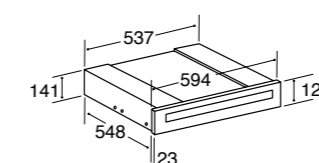
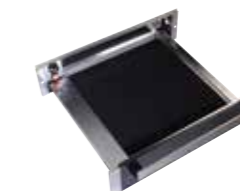

### VW152 Push-push warming drawer

Features

- Fan heat
- Temperature adjustable from 40°C to 80°C
- 6 place settings
- Smooth runners
- Non-slip silicone mat
- Power indicator light
- Push-push opening

Available in

- Stainless steel

Technical specification

- Rated electrical power: 0.44kW
- Power supply required: 3A
- Maximum capacity: 20kg

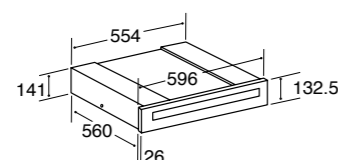

### VW281 Large warming drawer

Features

- Fan heat
- Temperature adjustable from 30°C to 80°C
- 12 place settings
- Smooth runners
- Non-slip silicone mat
- Power indicator light

Available in

- Stainless steel

Technical specification

- Rated electrical power: 432W max
- Power supply required: 3A
- Maximum capacity: 25kg

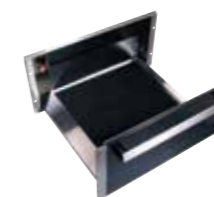
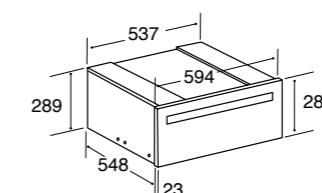

### VM100 Freestanding microwave oven



- Features**
- Auto defrost
  - Quick start
  - LED timer
  - 5 microwave power levels - 900W max
  - Interior lateral light
  - Acoustic end of programme signal
  - Left hand hinged door
  - Safety key lock

- Accessories**
- Glass turntable - 315mm diameter
  - Turntable ring

- Available in**
- Stainless steel

- Technical specification**
- Total useable capacity: 25L net
  - Rated electrical power: 1.45kW
  - Power supply required: 13A

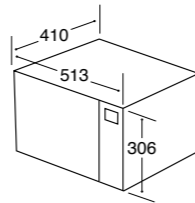

### VM130 Built-in microwave oven



Stainless steel



Black

- Features**
- Auto defrost
  - Quick start
  - LED timer
  - 5 microwave power levels - 900W max
  - Interior lateral light
  - Acoustic end of programme signal
  - Left hand hinged door
  - Safety key lock

- Accessories**
- Glass turntable - 315mm diameter
  - Turntable ring

- Available in**
- Stainless steel
  - Black

- Technical specification**
- Total useable capacity: 25L net
  - Rated electrical power: 1.45kW
  - Power supply required: 13A

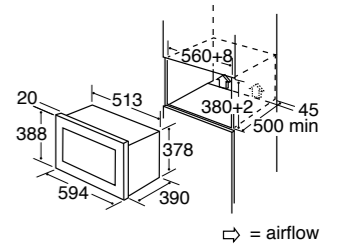

### VM200 Freestanding microwave oven and grill

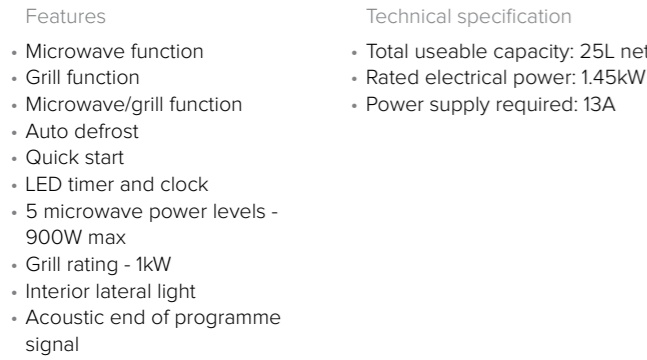

- Accessories**
- Glass turntable - 315mm diameter
  - Turntable ring
  - Trivet

- Available in**
- Stainless steel

- Technical specification**
- Total useable capacity: 25L net
  - Rated electrical power: 1.45kW
  - Power supply required: 13A

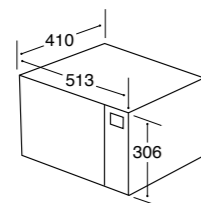

### VM230 Built-in microwave oven and grill

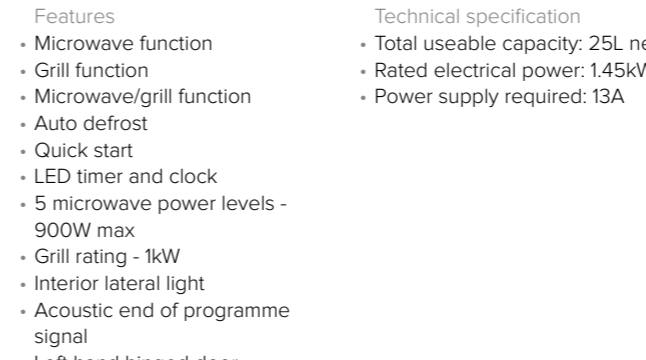

Stainless steel

- Accessories**
- Glass turntable - 315mm diameter
  - Turntable ring
  - Trivet

- Available in**
- Stainless steel
  - Black

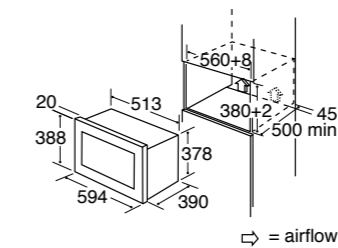

Black



## VM451 Built-in microwave oven, grill and convection oven

### Features

- Microwave function
- Grill function
- Convection oven function
- Microwave/grill function
- Microwave/convection oven function
- Grill/convection function
- Combination cooking function
- Auto defrost
- 10 auto-cook programmes
- Quick start
- LED timer and clock
- 5 microwave power levels - 900W max
- Grill rating - 1.1kW
- Convection oven rating - 2.5kW (maximum temperature on convection programme is 220°C)
- Interior lateral light
- Acoustic end of programme signal
- Left hand hinged door
- Safety key lock

### Accessories

- Glass turntable - 315mm diameter
- Turntable ring
- Trivet

### Available in

- Stainless steel

### Technical specification

- Total useable capacity: 25L net
- Rated electrical power: 2.5kW
- Power supply required: 13A

### Please note

- This microwave oven has a convection oven function but is not intended to be used as a substitute for a standard oven.
- Not suitable for built-under worktop fitting.

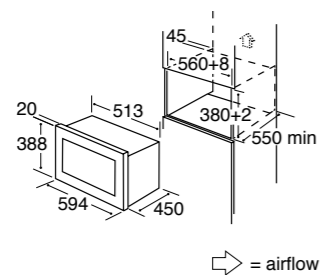

## VM550 Wall unit microwave oven

### Features

- Microwave function
- Manual defrost
- Auto defrost
- 8 auto-cook programmes
- Quick start
- LED timer and clock
- 5 microwave power levels - 700W max
- Interior lateral light
- Acoustic end of programme signal
- Left hand hinged door
- Safety key lock

### Accessories

- Glass turntable - 245mm diameter
- Turntable ring

### Available in

- Stainless steel

### Technical specification

- Total useable capacity: 17L net
- Rated electrical power: 1.05kW
- Power supply required: 5A

### Please note

- Not suitable for built-under worktop fitting.

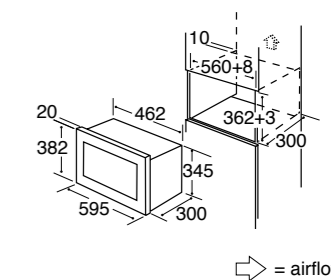



# Double ovens

Available in both built-in and built-under options, CDA A rated double ovens offer a winning combination of extra cooking space and outstanding features.

*Programmable timers on all double oven models allow you to automate cooking times, leaving you to get on with everything else.*

Double ovens

## DC740 and DC940 double ovens

Choose between the DC740 & DC940 for useful extra cooking space at either an under counter 'built-under' or eye level 'built-in' height and design your cooking space around you.



## DK751, DK951 and DK1151 double ovens

The DK751, DK951 & DK1151 models sharpen up the styling with black glass that is opaque until the internal light is switched on, providing uninterrupted clean lines throughout your kitchen when you are not cooking. With multi-function main ovens on these models you will have more flexibility in cooking style at your fingertips.

## DK1151 double tower oven

Our double tower oven, the DK1151 offers the flexibility of two full size single oven cavities combined into one appliance. What's more, each oven may be individually controlled and comes with full multi-function cooking options.



## 9Q6 Q-style double oven

Our Q-style double oven can be matched to a four or five burner gas hob and a stunning circular extractor which are all designed to perfectly complement each other.

## Quick guide to double ovens

The CDA range of double ovens includes both built-in and built-under models to suit your kitchen.

All double ovens are A rated in both oven cavities.



### DC740

- Built-under
- 4/3 functions
- Touch control programmer
- Available in stainless steel, white and black

More details on p54



### DC940

- Built-in
- 4/3 functions
- Touch control programmer
- Available in stainless steel, white and black

More details on p55



### DK751

- Built-under
- 3/8 functions
- Touch control programmer

More details on p56



### DK951

- Built-in
- 3/8 functions
- Touch control programmer

More details on p57



### DK1151

- Built-in tower oven
- 8/8 functions
- Touch control programmer

More details on p58



### 9Q6

- Built-in
- 3/10 functions
- Touch control programmer

More details on p59

*Choose from either a built-in double oven, to install and cook at eye level, or a built-under model that fits beneath your worktop making the most of low level space.*

**DC740** Built-under electric double oven

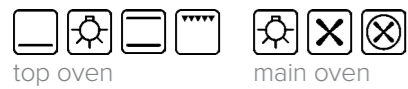

- Features**
- Easy clean enamel interior
  - Interior halogen lights
  - Cooling fan
  - Chromed rack sides with integrated anti-tilt shelves
  - Removable doors
  - Double glazed doors
  - Main oven
    - Touch control programmable electronic clock/timer

- Accessories**
- Grill pan with grid
  - 3 flat oven shelves

- Optional accessories**
- Pizza stone, ACG10
  - Glass oven tray, ACG20

- Available in**
- Stainless steel
  - Black
  - White

- Technical specification**
- Top oven useable capacity: 34L net
  - Main oven useable capacity: 50L net
  - Rated electrical power: 4.3kW
  - Power supply required: 20A
- Fitting note**
- Please ensure you check that there is sufficient clearance above built-under ovens when fitting the relevant hob.



Stainless steel  
White  
Black

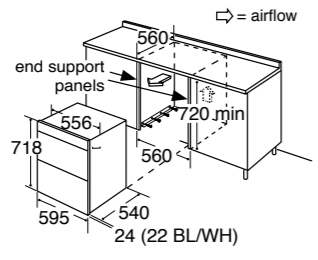

**DC940** Built-in electric double oven



- Features**
- Easy clean enamel interior
  - Interior halogen lights
  - Cooling fan
  - Chromed rack sides with integrated anti-tilt shelves
  - Removable doors
  - Double glazed doors
  - Main oven
    - Touch control programmable electronic clock/timer

- Accessories**
- Grill pan with grid
  - 3 flat oven shelves

- Optional accessories**
- Pizza stone, ACG10
  - Glass oven tray, ACG20

- Available in**
- Stainless steel
  - Black
  - White

- Technical specification**
- Top oven useable capacity: 34L net
  - Main oven useable capacity: 59L net
  - Rated electrical power: 4.3kW
  - Power supply required: 20A



Stainless steel  
White  
Black

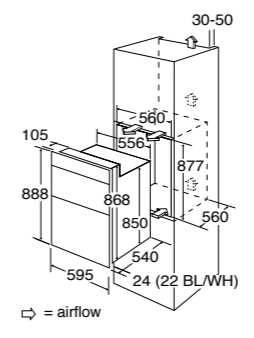

**DK751** Built-under electric double oven



Features

- Easy clean enamel interior
- Interior halogen lights
- Cooling fan
- Chromed rack sides with integrated anti-tilt shelves
- Double glazed removable doors with removable inner glass for easy cleaning
- Main oven
  - Touch control programmable electronic clock/timer

Accessories

- 2 flat oven shelves
- 1 space saver oven shelf
- 1 grill pan with grid
- 2 grill pan handles

Optional accessories

- Catalytic liners (top oven only), C6OL
- Catalytic liners (main oven only), C7OL
- Pizza stone, ACG10
- Glass oven tray, ACG20

Available in

- Stainless steel

Technical specification

- Top oven useable capacity: 37L net
- Main oven useable capacity: 50L net
- Rated electrical power: 4.08kW
- Power supply required: 20A

Fitting note

- Please ensure you check that there is sufficient clearance above built-under ovens when fitting the relevant hob.

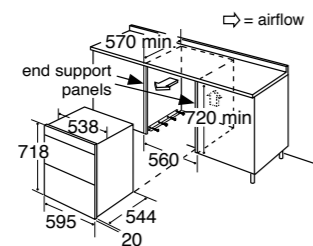

**DK951** Built-in electric double oven



Features

- Easy clean enamel interior
- Interior halogen lights
- Cooling fan
- Chromed rack sides with integrated anti-tilt shelves
- Double glazed removable doors with removable inner glass for easy cleaning
- Main oven
  - Touch control programmable electronic clock/timer
  - Lateral halogen light

Accessories

- 2 flat oven shelves
- 1 space saver oven shelf
- 1 grill pan with grid
- 2 grill pan handles

Optional accessories

- Catalytic liners (top oven only), C6OL
- Catalytic liners (lower oven only), C10OL
- Pizza stone, ACG10
- Glass oven tray, ACG20

Available in

- Stainless steel

Technical specification

- Top oven useable capacity: 37L net
- Main oven useable capacity: 59L net
- Rated electrical power: 4.4kW
- Power supply required: 20A

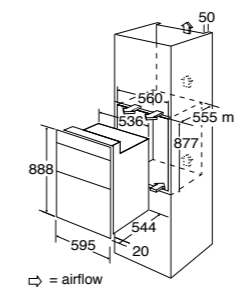

**DK1151** Built-in electric double tower oven



Features

- Easy clean enamel interior
- Interior halogen lights
- Lateral halogen lights
- Cooling fan
- Chromed rack sides with integrated anti-tilt shelves
- Double glazed removable doors with removable inner glass for easy cleaning
- Top oven
  - Touch control programmable electronic clock/timer

Accessories

- 2 flat oven shelves
- 2 space saver oven shelves
- 2 grill pans with grids
- 2 grill pan handles

Optional accessories

- Catalytic liners (2 required), C10OL
- Pizza stone, ACG10
- Glass oven tray, ACG20

Available in

- Stainless steel

Technical specification

- Top oven useable capacity: 59L net
- Bottom oven useable capacity: 59L net
- Rated electrical power: 4.77kW
- Power supply required: 25A



This double tower oven has the capacity of two full size ovens, providing plenty of cooking space.

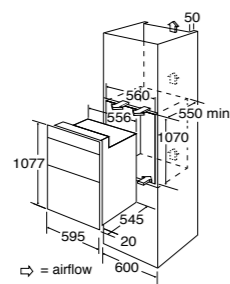

**9Q6** Built-in electric designer double oven

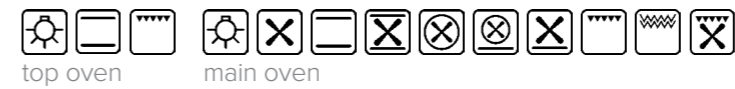

Features

- Easy clean enamel interior
- Interior halogen lights
- Cooling fan
- Chromed rack sides with integrated anti-tilt shelves
- Removable door
- Top oven
  - Double glazed cool door with removable inner glass for easy cleaning
- Main oven
  - Full touch control (functions and programmer)
  - Triple glazed cool door with removable glass for easy cleaning
  - Drop down grill
  - Lateral halogen light
  - Booster programme for rapid preheat

Accessories

- 2 flat oven shelves
- 1 space saver oven shelf
- 1 glass oven tray
- 1 grill pan with grid
- 2 grill pan handles
- Telescopic shelf kit (lower oven only)

Optional accessories

- Catalytic liners (top oven only), C6OL
- Catalytic liners (main oven only), C10OL
- Pizza stone, ACG10
- Glass oven tray, ACG20

Available in

- Stainless steel

Technical specification

- Top oven useable capacity: 37L net
- Main oven useable capacity: 59L net
- Rated electrical power: 5.6kW
- Power supply required: 25A

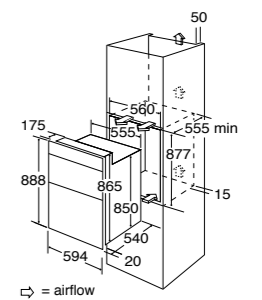

Co-ordinating products

The 9Q6 oven matches the EVQ7 extractor and the 4Q4 and 4Q5 hobs.

# Hobs

Everyone has their preference and we offer everything from bridging induction hobs to professional style gas hobs in sizes from domino to extra wide.

*Look out for our bridging induction hobs which allow you to turn two zones into one large induction surface, maximising your cooking space.*



## Induction hobs

Not only is an induction hob quick to reach temperature by transferring heat directly to the pan by electromagnetic induction, it also reduces the energy losses associated with heat escape making it more accurate to control. Choose induction for quicker cooking, an easy to clean hob surface and precision control.

The specific requirement for cooking on an induction hob is that only ferromagnetic pans will work (a magnet will stick to the base of the pan if it is compatible with induction hobs). High quality, flat based pans work best with induction and new pans will carry this symbol on the packaging to show they can be used:



## Best of both

Combining the best of cooking on induction with gas, the HNG7410 bridges both technologies with 4 induction zones plus a single gas wok burner. The induction side includes a timer, slider controls and extra safety features making it perfect for family cooking. With the addition of a gas burner, this model becomes suitable for most types of cookware and cooking styles.

## Ceramic hobs

Ceramic hobs are popular choices and are available in a wide range of sizes from 30cm through to 90cm. Choose between manual and touch control, also look out for dual and triple heating zones which are ideal for larger pans and stock pots.



## Gas hobs

Options range from single or two burner domino hobs to professional style six burner models for maximum cooking space. Our Q-style range and gas on glass designs add an aesthetic wow factor to your kitchen.



## Domino hobs

Combine multiple domino hobs to create a flexible work area with a variety of cooking styles. Choose from gas, ceramic, induction or even a ceramic griddle.



# Quick guide to gas hobs

Our range of gas hobs offers a wide choice. This comprehensive collection includes 1 and 2 burner domino hobs, functional 4 burner hobs and stunning 5 and 6 burner hobs for the most professional kitchen.

We have included beautiful, solid cast iron pan supports as standard with most of our hobs, whilst the HCG301, HG6150 and HG6250 have enamelled pan supports if you prefer a dishwasher option.



All CDA gas hobs have automatic ignition and a flame failure device "Flame Safe," as standard.

Flame Safe is a feature designed to close off the gas supply in the event that a burner is accidentally extinguished.

## Gas



### HCG301

- 2 burners
  - Enamel pan support
  - Front control
- More details on p64



### HG6150

- 4 burners
  - Enamel pan supports
  - Side control
- More details on p64

## Gas



### HG7500

- 4 burners
  - Cast iron pan supports
  - 2 wok burners (1 dual control)
  - Front control
- More details on p66



### HG9350

- 5 burners
  - Cast iron pan supports
  - Wok burner
  - Front control
- More details on p67

## Gas on glass



### HG3601

- Single burner gas on glass
  - Cast iron pan support
  - Wok burner
  - Front control
- More details on p69



### HG3602

- 2 burner gas on glass
  - Cast iron pan supports
  - Front control
- More details on p69

## Gas on glass



### HVG620

- 4 burner gas on glass
  - Cast iron pan supports
  - Front control
  - Available in stainless steel and black
- More details on p68



### HVG720

- 5 burner gas on glass
  - Cast iron pan supports
  - Wok burner
  - Front control
  - Available in stainless steel and black
- More details on p68

## Gas



### HG6250

- 4 burners
  - Enamel pan supports
  - Wok burner
  - Front control
  - Available in stainless steel and black
- More details on p64



### HG6350

- 4 burners
  - Cast iron pan supports
  - Wok burner
  - Front control
- More details on p65



### HG7250

- 5 burners
  - Cast iron pan supports
  - Wok burner
  - Front control
- More details on p65



### HG7350

- 5 burners
  - Cast iron pan supports
  - Wok burner
  - Front control
- More details on p65

## Gas



### HG9320

- 6 burners
  - Cast iron pan supports
  - Wok burner
  - Side control
- More details on p67

## Gas on glass



### HVG66

- 4 burner gas on glass
  - Cast iron pan supports
  - Front control
- More details on p69



### HVG77

- 5 burner gas on glass
  - Cast iron pan supports
  - Wok burner
  - Front control
- More details on p70



### HVG96

- 5 burner gas on glass
  - Cast iron pan supports
  - Wok burner
  - Front control
- More details on p70



### HVG93

- 4 burner gas on glass
  - Cast iron pan supports
  - Wok burner
  - Front control
- More details on p70

## Q-style



### 4Q4

- 4 burner
  - Cast iron pan supports
  - Front control
- More details on p71



### 4Q5

- 5 burner
  - Cast iron pan supports
  - Central wok burner
  - Front control
- More details on p71

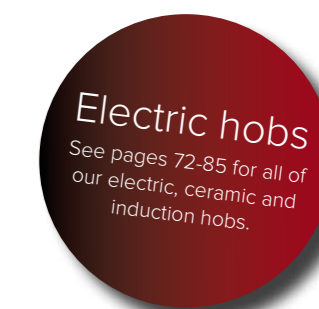



### HCG301 Domino two burner gas hob

- Features**
- Front control
  - Enamel pan support
  - Automatic ignition
  - Flame failure included
- Accessories**
- LPG conversion kit included
- Optional accessories**
- Domino joint strip, AHJ30
- Available in**
- Stainless steel

- Technical specification**
- Burners:**
- Front, semi-rapid: 1.75kW
  - Rear, rapid: 3kW
- Rated gas input: 4.75kW
  - Rated electrical power: 1W
  - Power supply required: 3A

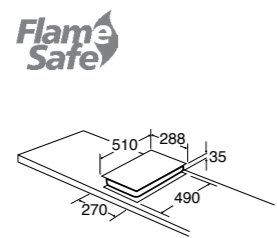

### HG6350 Four burner gas hob

- Features**
- Front control
  - Cast iron pan supports
  - Automatic ignition
  - Flame failure included
  - Wok burner
- Accessories**
- Wok support
  - LPG conversion kit included
- Available in**
- Stainless steel
  - LPG gas version, HG6350LSS

- Technical specification**
- Burners:**
- Front left, triple ring/wok: 3.8kW
  - Front right, auxiliary: 1kW
  - Rear left, semi-rapid: 1.75kW
  - Rear right, semi-rapid: 1.75kW
- Rated gas input: 8.3kW
  - Rated electrical power: 1W
  - Power supply required: 3A

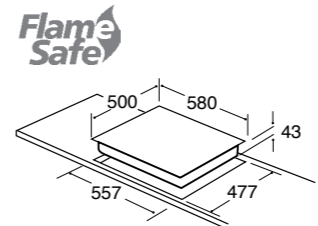

### HG6150 Four burner gas hob

- Features**
- Side control
  - Enamel pan supports
  - Automatic ignition
  - Flame failure included
- Accessories**
- LPG conversion kit included
- Available in**
- Stainless steel

- Technical specification**
- Burners:**
- Front left, rapid: 3kW
  - Front right, auxiliary: 1kW
  - Rear left, semi-rapid: 1.75kW
  - Rear right, semi-rapid: 1.75kW
- Rated gas input: 7.5kW
  - Rated electrical power: 1W
  - Power supply required: 3A

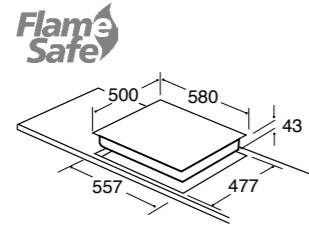

### HG7250 Five burner gas hob

- Features**
- Front control
  - Cast iron pan supports
  - Automatic ignition
  - Flame failure included
  - Wok burner
- Accessories**
- Wok support
  - LPG conversion kit included
- Available in**
- Black

- Technical specification**
- Burners:**
- Front left, rapid: 3kW
  - Front right, auxiliary: 1kW
  - Centre, triple ring/wok: 3.8kW
  - Rear left, semi-rapid: 1.75kW
  - Rear right, semi-rapid: 1.75kW
- Rated gas input: 11.3kW
  - Rated electrical power: 2W
  - Power supply required: 3A

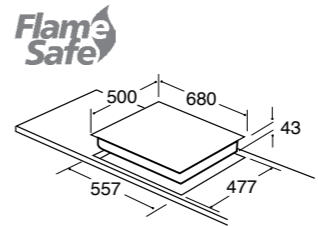

### HG6250 Four burner gas hob

- Features**
- Front control
  - Enamel pan supports
  - Automatic ignition
  - Flame failure included
  - Wok burner
- Accessories**
- LPG conversion kit included
- Available in**
- Stainless steel
  - Black

- Technical specification**
- Burners:**
- Front left, triple ring/wok: 3.8kW
  - Front right, auxiliary: 1kW
  - Rear left, semi-rapid: 1.75kW
  - Rear right, semi-rapid: 1.75kW
- Rated gas input: 8.3kW
  - Rated electrical power: 1W
  - Power supply required: 3A

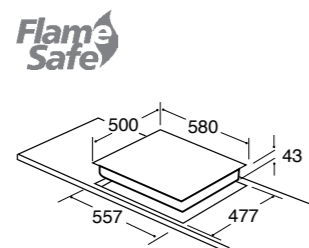

Stainless steel



Black

### HG7350 Five burner gas hob

- Features**
- Front control
  - Cast iron pan supports
  - Automatic ignition
  - Flame failure included
  - Wok burner
- Accessories**
- Wok support
  - LPG conversion kit included
- Available in**
- Stainless steel

- Technical specification**
- Burners:**
- Front left, semi-rapid: 1.75kW
  - Front right, auxiliary: 1kW
  - Centre, triple ring/wok: 3.8kW
  - Rear left, semi-rapid: 1.75kW
  - Rear right, rapid: 3kW
- Rated gas input: 11.3kW
  - Rated electrical power: 2W
  - Power supply required: 3A

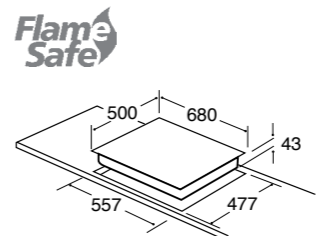

## HG7500 Four burner gas hob

### Features

- 2 wok burners (1 dual control)
- Front control
- Cast iron pan supports
- Automatic ignition
- Flame failure included

### Accessories

- Wok support (not shown)
- LPG conversion kit included

### Available in

- Stainless steel

### Technical specification

#### Burners:

- Rear central, semi-rapid: 1.75kW
- Right, triple ring/wok: 3.5kW
- Front central, auxiliary: 1kW
- Left, dual burner: 4.2kW

- Rated gas input: 10.45kW
- Rated electrical power: 1W
- Power supply required: 3A

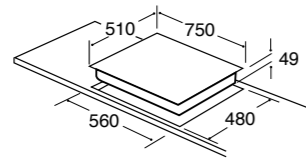

## HG9350 Five burner gas hob

### Features

- Wok burner
- Front control
- Cast iron pan supports
- Automatic ignition
- Flame failure included

### Accessories

- Wok support
- LPG conversion kit included

### Available in

- Stainless steel

### Technical specification

#### Burners:

- Front central, auxiliary: 1kW
- Front right, semi-rapid burner: 1.75kW
- Left, wok burner: 3.8kW
- Rear central, rapid burner: 3kW
- Rear right, semi-rapid: 1.75kW

- Rated gas input: 11.3kW
- Rated electrical power: 2W
- Power supply required: 3A

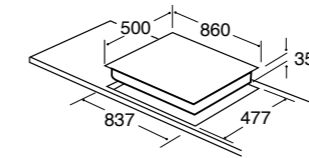

## HG9320 Six burner gas hob

### Features

- Wok burner
- Side control
- Cast iron pan supports
- Automatic ignition
- Flame failure included

### Accessories

- Wok support
- LPG conversion kit included

### Available in

- Stainless steel

### Technical specification

#### Burners:

- Front left, triple ring/wok: 3.5kW
- Front centre, auxiliary: 1kW
- Front right, auxiliary: 1kW
- Rear left, semi-rapid: 1.75kW
- Rear centre, rapid: 3kW
- Rear right, semi-rapid: 1.75kW

- Rated gas input: 12kW
- Rated electrical power: 1.1W
- Power supply required: 3A

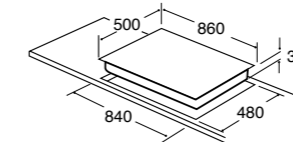

### HVG620 Four burner gas on glass hob

**Features**

- Bevelled edges
- Front control
- Cast iron pan supports
- Automatic ignition
- Flame failure included

**Accessories**

- LPG conversion kit included

**Available in**

- Stainless steel
- Black

**Technical specification**

**Burners:**

- Front left, rapid: 3kW
- Front right, auxiliary: 1kW
- Rear left, semi-rapid: 1.75kW
- Rear right, semi-rapid: 1.75kW

- Rated gas input: 7.5kW
- Rated electrical power: 1.1W
- Power supply required: 3A

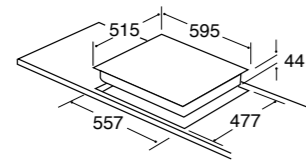

Black



Stainless steel

Bevelled glass edges

### HVG720 Five burner gas on glass hob

**Features**

- Bevelled edges
- Front control
- Wok burner
- Cast iron pan supports
- Automatic ignition
- Flame failure included

**Accessories**

- Wok support (not shown)
- LPG conversion kit included

**Available in**

- Stainless steel
- Black

**Technical specification**

**Burners:**

- Front left, auxiliary: 1kW
- Front right, semi-rapid: 1.75kW
- Centre, wok: 3.8kW
- Rear left, rapid: 3kW
- Rear right, semi-rapid: 1.75kW

- Rated gas input: 11.3kW
- Rated electrical power: 1.1W
- Power supply required: 3A

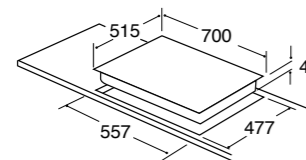

Black



Stainless steel

Bevelled glass edges

### HG3601 Domino single burner gas on glass hob

**Features**

- Wok burner
- Front control
- Cast iron pan supports
- Automatic ignition
- Flame failure included

**Accessories**

- Wok support (not shown)
- LPG conversion kit included

**Available in**

- Frameless

**Technical specification**

**Burner:**

- Centre, triple ring/wok: 3.5kW
- Rated gas input: 3.5kW
- Rated electrical power: 1W
- Power supply required: 3A

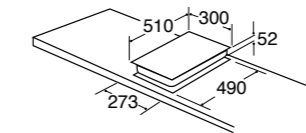

### HG3602 Domino two burner gas on glass hob

**Features**

- Front control
- Cast iron pan supports
- Automatic ignition
- Flame failure included

**Accessories**

- LPG conversion kit included

**Available in**

- Frameless

**Technical specification**

**Burners:**

- Front, semi-rapid: 1.75kW
- Rear, rapid: 3kW

- Rated gas input: 4.75kW
- Rated electrical power: 1W
- Power supply required: 3A

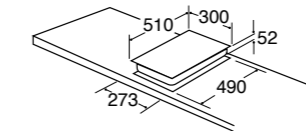

### HVG66 Four burner gas on glass hob

**Features**

- Front control
- Cast iron pan supports
- Automatic ignition
- Flame failure included

**Accessories**

- LPG conversion kit included

**Available in**

- Black

**Technical specification**

**Burners:**

- Front left, auxiliary: 1kW
- Front right, semi-rapid: 1.75kW
- Rear left, rapid: 3kW
- Rear right, semi-rapid: 1.75kW

- Rated gas input: 7.5kW
- Rated electrical power: 1W
- Power supply required: 3A

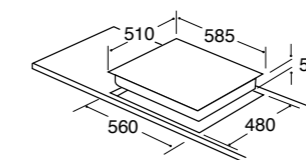

### HVG77 Five burner gas on glass hob

**Features**

- Wok burner
- Front control
- Cast iron pan supports
- Automatic ignition
- Flame failure included

**Accessories**

- Wok support
- LPG conversion kit included

**Available in**

- Black

**Technical specification**

**Burners:**

- Front left, rapid: 3kW
- Front right, auxiliary: 1kW
- Centre, wok: 3.5kW
- Rear left, semi-rapid: 1.75kW
- Rear right, semi-rapid: 1.75kW

- Rated gas input: 11kW
- Rated electrical power: 1W
- Power supply required: 3A

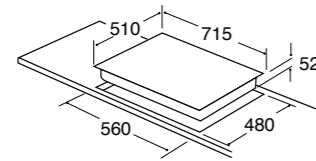

### HVG96 Five burner gas on glass hob

**Features**

- Wok burner
- Front control
- Cast iron pan supports
- Automatic ignition
- Flame failure included

**Accessories**

- Wok support (not shown)
- LPG conversion kit included

**Available in**

- Black

**Technical specification**

**Burners:**

- Front left, rapid: 3kW
- Front centre, auxiliary: 1kW
- Centre right, wok: 3.5kW
- Rear left, semi-rapid: 1.75kW
- Rear centre, semi-rapid: 1.75kW

- Rated gas input: 11kW
- Rated electrical power: 1W
- Power supply required: 3A

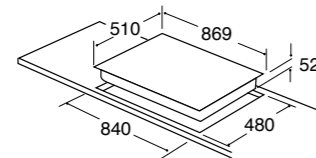

### HVG93 Four burner gas on glass linear hob

**Features**

- Wok burner
- Front control
- Cast iron pan supports
- Automatic ignition
- Flame failure included

**Accessories**

- Wok support (not shown)
- LPG conversion kit included

**Available in**

- Black

**Technical specification**

**Burners:**

- Left, wok: 3.5kW
- Centre left, auxiliary: 1kW
- Centre right, semi-rapid: 1.75kW
- Right, rapid: 3kW

- Rated gas input: 9.25kW
- Rated electrical power: 1W
- Power supply required: 3A

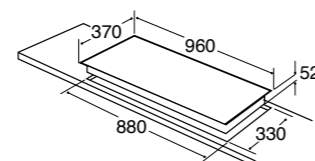

**Co-ordinating products**

This hob matches the 3D9 and EDD91 downdraft extractors.



### 4Q4 Four burner Q-style gas hob

**Features**

- Front control
- Cast iron pan supports
- Automatic ignition
- Flame failure included

**Accessories**

- LPG conversion kit included

**Available in**

- Stainless steel

**Technical specification**

**Burners:**

- Front left, auxiliary: 1kW
- Front right, semi-rapid: 1.75kW
- Rear left, rapid: 3kW
- Rear right, semi-rapid: 1.75kW

- Rated gas input: 7.5kW
- Rated electrical power: 1W
- Power supply required: 3A

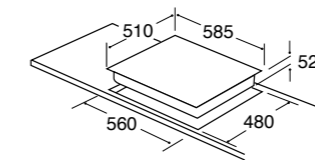

**Co-ordinating products**

This hob matches the 6Q5 and 9Q6 ovens as well as the EVQ7 extractor.

### 4Q5 Five burner Q-style gas hob

**Features**

- Wok burner
- Front control
- Cast iron pan supports
- Automatic ignition
- Flame failure included

**Accessories**

- Wok support
- LPG conversion kit included

**Available in**

- Stainless steel

**Technical specification**

**Burners:**

- Front left, rapid: 3kW
- Front right, auxiliary: 1kW
- Centre, wok: 3.5kW
- Rear left, semi-rapid: 1.75kW
- Rear right, semi-rapid: 1.75kW

- Rated gas input: 11kW
- Rated electrical power: 1W
- Power supply required: 3A

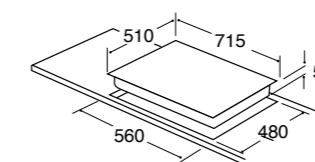

**Co-ordinating products**

This hob matches the 6Q5 and 9Q6 ovens as well as the EVQ7 extractor.

# Quick guide to electric hobs

Our range of electric hobs includes a comprehensive selection of both manual and touch control 2, 4 and 5 zone ceramic hobs, high-tech induction hobs and domino hobs which you can put together in different combinations to suit your requirements.

All CDA ceramic and induction hobs have the following features:

- Easy clean surface
- Shatterproof ceramic safety glass
- Residual heat indicators

## Domino



### HCC310

- Griddle domino hob
  - Front control
  - Stainless steel
- More details on p74



### HCE340

- 2 plate electric domino hob
  - Front control
  - Stainless steel
- More details on p74

## Electric



### HE6051

- 4 plate electric hob
  - Side control
  - Stainless steel
- More details on p74

## Ceramic



### HC3621

- 2 zone ceramic domino hob
  - Front touch control
- More details on p75

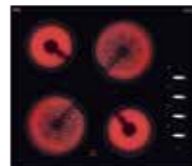

### HC6211

- 4 zone ceramic hob
  - Side control
- More details on p75

## Ceramic

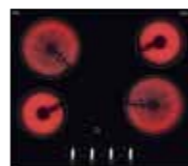

### HC6311

- 4 zone ceramic hob
  - Front control
- More details on p76

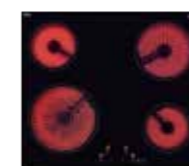

### HC6621

- 4 zone ceramic hob
  - Front touch control
- More details on p76



### HC7621

- 5 zone ceramic hob
  - Front touch control
- More details on p76

## Ceramic



### HC9621

- 5 zone ceramic hob
  - Front touch control
- More details on p77



### HC9626

- 4 zone ceramic hob
  - Front touch control
- More details on p77

## Induction



### HN3621

- 2 zone domino induction hob
  - Front touch control
- More details on p78



### HN6111

- 4 zone induction hob
  - Front touch control
- More details on p78

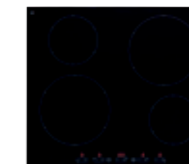

### HN6411

- 4 zone eco induction hob
  - Front touch control
- More details on p79



### HN6731

- 4 zone induction hob
  - Front touch control
  - Bridging function
- More details on p80

## Induction



### HN6841

- 4 zone induction hob
  - Front touch control
  - Bridging function
  - Illuminated front edge
- More details on p81



### HN9611

- 5 zone induction hob
  - Front touch control
  - Bridging function
- More details on p82

## Induction

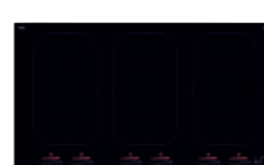

### HN9841

- 6 zone induction hob
  - Front touch control
  - Bridging function
- More details on p83



### HN9626

- 4 zone induction hob
  - Front touch control
- More details on p84



### HNG7410

- 4 zone induction hob
  - Single wok burner
  - Front touch control
- More details on p85

## Indu-gas



### HCC310 Domino griddle hob

- Features
- Single ceramic griddle - cook directly on glass
  - 12 power levels with indicator light
  - Front control
  - Easy clean surface

- Technical specification
- Rated electrical power: 1.3kW
  - Power supply required: 13A

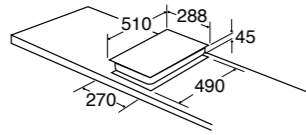

- Optional accessories
- Domino joining strip, AHJ30

- Available in
- Stainless steel

### HC3621 Domino two zone ceramic hob

- Features
- Front control
  - Electronic touch control
  - 9 power levels
  - Easy clean surface
  - Ceramic shatterproof safety glass
  - Residual heat indicators
  - Overflow detection
  - 99 minute timer
  - LED display
  - Safety key lock
  - Auto safety switch off
  - Temperature limiter
  - Time limit security system

- Technical specification
- Zones:
- Front, 145mm: 1.2kW
  - Rear, 180mm: 1.8kW
- Rated electrical power: 3kW
  - Power supply required: 13A

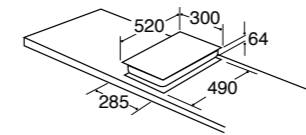

- Available in
- Frameless

### HCE340 Domino two plate electric hob

- Features
- Front control
  - 6 power levels with indicator light
  - 2 rapid plates

- Technical specification
- Hot plates:
- Front, 145mm rapid: 1.5kW
  - Rear, 180mm rapid: 2kW
- Rated electrical power: 3.5kW
  - Power supply required: 20A

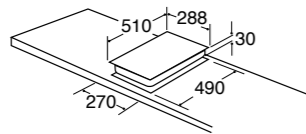

- Optional accessories
- Domino joining strip, AHJ30

- Available in
- Stainless steel



### HC6211 Four zone ceramic hob

- Features
- Side control
  - 6 power levels with indicator light
  - Easy clean surface
  - Ceramic shatterproof safety glass
  - Residual heat indicators
  - Temperature limiter

- Technical specification
- Zones:
- Front left, 180mm: 1.8kW
  - Front right, 145mm: 1.2kW
  - Rear left, 145mm: 1.2kW
  - Rear right, 180mm: 1.8kW
- Rated electrical power: 6.0kW
  - Power supply required: 30A

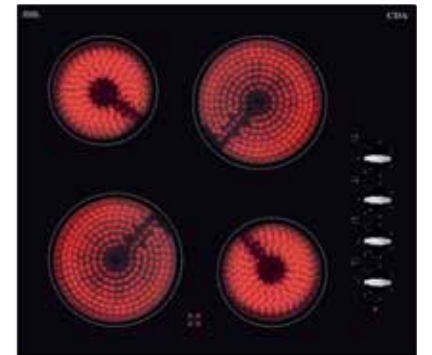
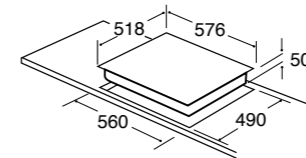

- Available in
- Frameless

### HE6051 Four plate electric hob

- Features
- Side control
  - 6 power levels with indicator light
  - 2 rapid plates

- Technical specification
- Hot plates:
- Front left, 180mm rapid: 2kW
  - Front right, 145mm: 1kW
  - Rear left, 145mm rapid: 1.5kW
  - Rear right, 180mm: 1.5kW
- Rated electrical power: 6.0kW
  - Power supply required: 30A

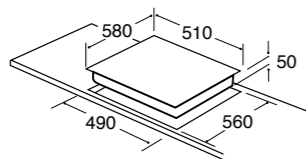

### HC6311 Four zone ceramic hob

**Features**

- Front control
- 6 power levels with indicator light
- Easy clean surface
- Ceramic shatterproof safety glass
- Residual heat indicators
- Temperature limiter

**Technical specification**

- Zones:**
- Front left, 180mm: 1.8kW
  - Front right, 145mm: 1.2kW
  - Rear left, 145mm: 1.2kW
  - Rear right, 180mm: 1.8W
- Rated electrical power: 6.0kW
  - Power supply required: 30A

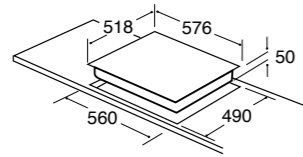
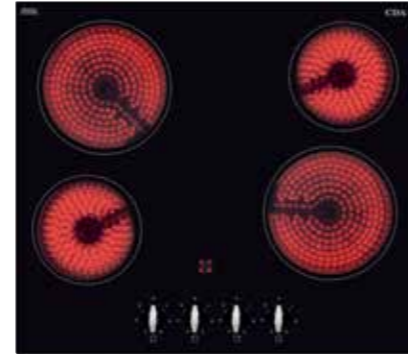

**Available in**

- Frameless

### HC6621 Four zone ceramic hob

**Features**

- Front control
- Electronic touch control
- 9 power levels
- Easy clean surface
- Ceramic shatterproof safety glass
- Residual heat indicators
- Overflow detection
- Overheat detection
- LED display
- Safety key lock
- Auto safety switch off
- Temperature limiter
- Time limit security system

**Technical specification**

- Zones:**
- Front left, 210mm: 2.3kW
  - Front right, 145mm: 1.2kW
  - Rear left, 145mm: 1.2kW
  - Rear right, 180mm: 1.8W
- Rated electrical power: 6.5kW
  - Power supply required: 30A

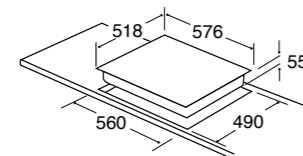
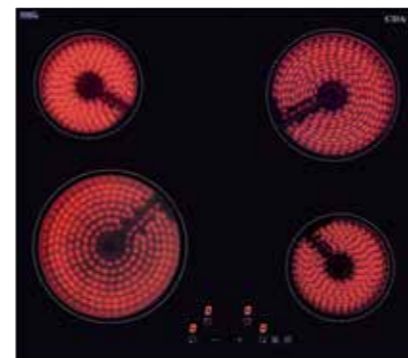

**Available in**

- Frameless

### HC7621 Five zone ceramic hob

**Features**

- Front control
- Electronic touch control
- 9 power levels
- Easy clean surface
- Ceramic shatterproof safety glass
- Residual heat indicators
- 99 minute timer
- LED display
- Safety key lock
- Overflow detection
- Overheat detection
- Auto safety switch off
- Time limit security system
- Temperature limiter

**Technical specification**

- Zones:**
- Front left (triple): -120mm: 0.8kW -175mm: 1.6kW -210mm: 2.3kW
  - Front right, 145mm: 1.2kW
  - Centre (dual): -170mm: 1.5kW -256mm: 2.2kW
  - Rear left, 145mm: 1.2kW
  - Rear right, 180mm: 1.8kW
- Rated electrical power: 8.7kW
  - Power supply required: 40A

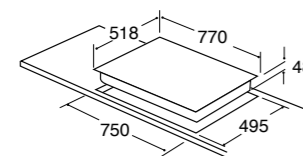
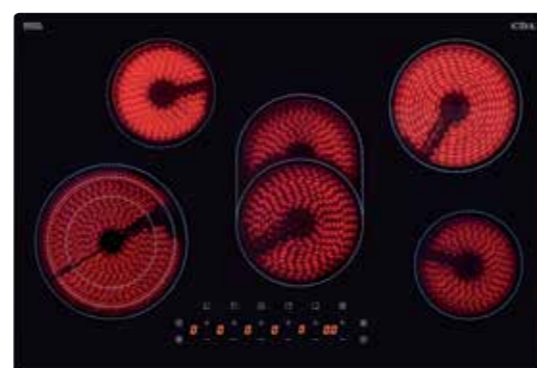

**Available in**

- Frameless

### HC9621 Five zone ceramic hob

**Features**

- Front control
- Electronic touch control
- 9 power levels
- Easy clean surface
- Ceramic shatterproof safety glass
- Residual heat indicators
- 99 minute timer
- LED display
- Safety key lock
- Overflow detection
- Overheat detection
- Auto safety switch off
- Time limit security system
- Temperature limiter

**Technical specification**

- Zones:**
- Front left (triple): -120mm: 0.8kW -175mm: 1.6kW -210mm: 2.3kW
  - Front right, 145mm: 1.2kW
  - Centre (dual): -170mm: 1.5kW -256mm: 2.2kW
  - Rear left, 145mm: 1.2kW
  - Rear right, 180mm: 1.8kW
- Rated electrical power: 8.7kW
  - Power supply required: 40A

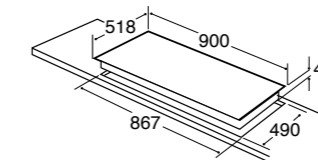
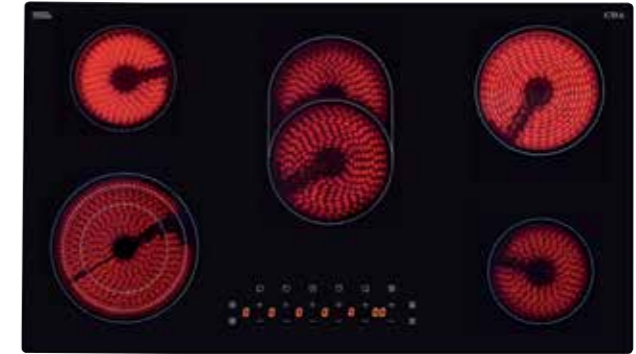

**Available in**

- Frameless

### HC9626 Four zone ceramic linear hob

**Features**

- Front control
- Electronic touch control
- 9 power levels
- Easy clean surface
- Ceramic shatterproof safety glass
- Residual heat indicators
- 99 minute timer
- LED display
- Safety key lock
- Overflow detection
- Overheat detection
- Auto safety switch off
- Time limit security system
- Temperature limiter

**Technical specification**

- Zones:**
- Front left (triple): -120mm: 0.8kW -175mm: 1.6kW -210mm: 2.3kW
  - Centre left, 145mm: 1.2kW
  - Centre right (dual): -120mm: 0.7kW -180mm: 1.7kW
  - Front right (dual): -120mm: 0.7kW -180mm: 1.7kW
- Rated electrical power: 6.9kW
  - Power supply required: 30A



**Available in**

- Frameless



**Co-ordinating product**

This hob matches the 3D9 and EDD91 downdraft extractors, together they will both fit into a standard 600mm worktop depth.

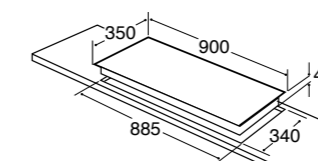

## HN3621 Domino two zone induction hob

### Features

- Front control
- Electronic touch control
- 9 power levels
- Timer
- Keep warm function
- Easy clean surface
- Ceramic shatterproof safety glass
- Residual heat indicators
- Overflow detection
- Overheat detection
- Automatic pan detection
- Small object detection
- LED display
- Safety key lock
- Auto safety switch off
- Time limit security system

### Available in

- Frameless

### Technical specification

#### Zones:

- Front, 160mm: 1.4kW
- Rear, 160mm: 1.4kW

- Rated electrical power: 2.8kW
- Power supply required: 13A

#### Fitting note

- Please ensure that you check that there is sufficient clearance when fitting induction hobs over both single and built-under double ovens and that adequate ventilation is provided.

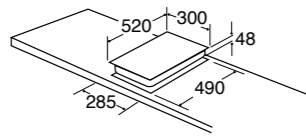

## HN6111 Four zone induction hob

### Features

- Front control
- Electronic touch control
- 9 power levels
- Booster function on all zones
- 99 minute timer
- Keep warm function
- Easy clean surface
- Ceramic shatterproof safety glass
- Residual heat indicators
- Overflow detection
- Overheat detection
- Automatic pan detection
- Small object detection
- LED display
- Safety key lock
- Auto safety switch off
- Time limit security system

### Available in

- Frameless

### Technical specification

#### Zones:

- Front left, 210mm: 2kW, 3kW with booster
- Front right, 160mm: 1.2kW, 1.4kW with booster
- Rear left, 160mm: 1.2kW, 1.4kW with booster
- Rear right, 210mm: 2kW, 3kW with booster

- Rated electrical power: 7.4kW
- Power supply required: 32A

#### Fitting note

- Please ensure that you check that there is sufficient clearance when fitting induction hobs over both single and built-under double ovens and that adequate ventilation is provided.

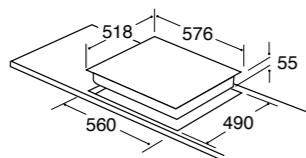

## HN6411 Four zone eco induction hob

### Features

- Front control
- Electronic touch control
- 9 power levels
- Booster function on all zones
- Easy clean surface
- Residual heat indicators
- Overheat detection
- Overflow detection
- Automatic pan detection
- Small object detection
- Power share system
- LED display
- 99 minute timer
- Safety key lock
- Auto safety switch off
- Time limit security system

### Available in

- Frameless

### Technical specification

#### Zones:

- Front left, 210mm: 1.5kW, 2kW with booster
- Front right, 145mm: 1.2kW, 1.6kW with booster
- Rear left, 145mm: 1.2kW, 1.6kW with booster
- Rear right, 210mm: 1.5kW, 2kW with booster

- Rated electrical power: 2.8/3.5/6/7.2kW (configurable)
- Power supply required: 13-32A (configurable)

- If the hob is configured for use with a supply below 32A, the hob will automatically regulate the power consumption so as not to exceed the power available.

#### Fitting note

- Please ensure that you check that there is sufficient clearance when fitting induction hobs over both single and built-under double ovens and that adequate ventilation is provided.

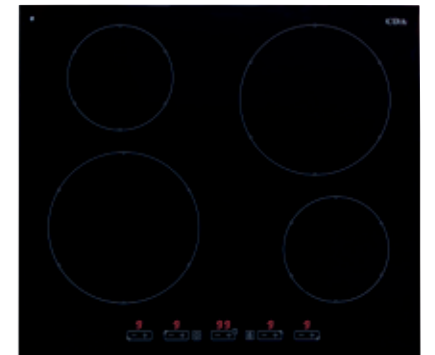
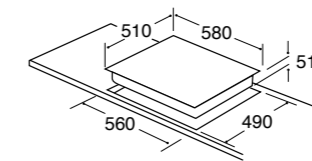



Our bridging induction hobs provide maximum flexibility, allowing you to turn two zones into one large induction surface for cooking with larger pots and pans.

**HN6731** Four zone induction hob

- Features
- Electronic touch control
  - Front control
  - Left zones bridging function
  - 9 power levels
  - Booster function on all zones
  - 99 minute timer
  - Pause/restart function
  - Keep warm function
  - Easy clean surface
  - Ceramic shatterproof safety glass
  - Residual heat indicators
  - Overflow detection
  - Overheat detection
  - Automatic pan detection
  - Small object detection
  - LED display
  - Safety key lock
  - Auto safety switch off
  - Time limit security system

- Technical specification
- Zones:
- Front left: 160mm, 1.4kW, 2kW with booster
  - Front right: 160mm, 1.2kW, 1.4kW with booster
  - Rear left: 160mm, 1.2kW, 1.4kW with booster
  - Rear right: 210mm, 2.3kW, 3kW with booster
- Rated electrical power: 7.1kW
  - Power supply required: 32A

- Fitting note
- Please ensure that you check that there is sufficient clearance when fitting induction hobs over both single and built-under double ovens and that adequate ventilation is provided.



**Keep warm function**  
 Select this function to maintain a programmed 70°C temperature on each zone, for up to 2 hours.

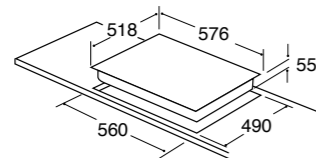

- Available in
- Frameless

**HN6841** Four zone induction hob with illuminated front edge

- Features
- Side bevelled edges
  - Illuminated front edge
  - Front control
  - Electronic touch and slide control
  - 9 power levels
  - Booster function on all zones
  - Left zones can be bridged
  - Right zones can be bridged
  - 99 minute timer
  - Pause/restart function
  - Melt function
  - Keep warm function
  - Simmer function
  - Easy clean surface
  - Ceramic shatterproof safety glass
  - Residual heat indicators
  - Overflow detection
  - Overheat detection
  - Automatic pan detection
  - Small object detection
  - LED display
  - Safety key lock
  - Auto safety switch off
  - Time limit security system

- Technical specification
- Zones:
- Front left: 220mm x 190mm, 2.2kW, 3.7kW with booster
  - Front right: 220mm x 190mm, 2.2kW, 3.7kW with booster
  - Rear left: 220mm x 190mm, 2.2kW, 3.7kW with booster
  - Rear right: 220mm x 190mm, 2.2kW, 3.7kW with booster
- Rated electrical power: 7.4kW
  - Power supply required: 32A

- Fitting note
- Please ensure that you check that there is sufficient clearance when fitting induction hobs over both single and built-under double ovens and that adequate ventilation is provided.



Side bevelled glass edges

**Illuminated edge**  
 Illuminated front edge serves to indicate that the hob surface is still hot.



Illuminated front edge

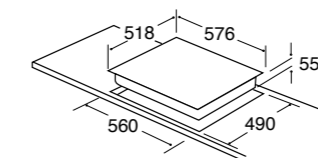

- Available in
- Frameless

## HN9611 Five zone induction hob

### Features

- Front control
- Electronic touch control
- Left zones bridging function
- Right zones bridging function
- 9 power levels
- Booster function on all zones
- 99 minute timer
- Pause/restart function
- Melt function
- Keep warm function
- Simmer function
- Easy clean surface
- Ceramic shatterproof safety glass
- Residual heat indicators
- Overflow detection
- Overheat detection
- Automatic pan detection
- Small object detection
- LED display
- Safety key lock
- Auto safety switch off
- Time limit security system

### Available in

- Frameless

### Technical specification

#### Zones:

- Front left: 210mm, 2.1kW, 3.7kW with booster
- Front right: 210mm, 2.1kW, 3.7kW with booster
- Rear left: 210mm, 2.1kW, 3.7kW with booster
- Rear centre: 260mm, 2.6kW, 3.7kW with booster
- Rear right: 210mm, 2.1kW, 3.7kW with booster

- Rated electrical power: 11.1kW
- Power supply required: 45A

#### Fitting note

- Please ensure that you check that there is sufficient clearance when fitting induction hobs over both single and built-under double ovens and that adequate ventilation is provided.

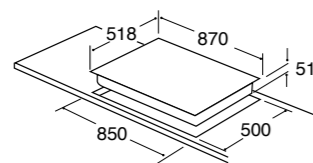

## HN9841 Six zone induction hob

### Features

- Front control
- Electronic touch and slide control
- Left zones bridging function
- Centre zones bridging function
- Right zones bridging function
- 9 power levels
- Booster function on all zones
- 99 minute timer
- Pause/restart function
- Melt function
- Keep warm function
- Simmer function
- Easy clean surface
- Ceramic shatterproof safety glass
- Residual heat indicators
- Overflow detection
- Automatic pan detection
- Small object detection
- LED display
- Safety key lock
- Auto safety switch off
- Time limit security system
- Temperature limiter
- Side and front bevelled edges

### Available in

- Frameless

### Technical specification

#### Zones:

- Front left, 220mm: 2.1kW, 3.7kW with booster
- Front centre, 220mm: 2.1kW, 3.7kW with booster
- Front right, 220mm: 2.1kW, 3.7kW with booster
- Rear left, 220mm: 2.1kW, 3.7kW with booster
- Rear centre, 220mm: 2.1kW, 3.7kW with booster
- Rear right, 220mm: 2.1kW, 3.7kW with booster
- Rated electrical power: 11.1kW
- Power supply required: 45A

#### Fitting notes

- Please ensure that you check that there is sufficient clearance when fitting the induction hobs over both single and built-under double ovens and that adequate ventilation is provided.

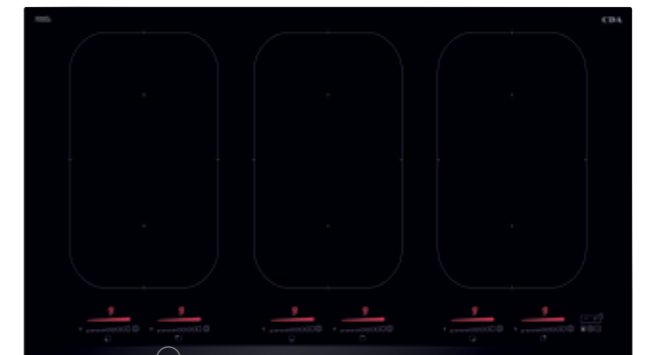

Side bevelled glass edges

**Melt function**  
Use the melt function to slowly warm delicate foods that are prone to burning, such as chocolate or butter.

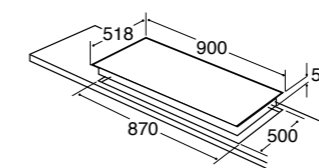



The HNG7410 bridges both technologies with 4 induction zones plus a single gas wok burner.

## HN9626 Four zone linear induction hob

### Features

- Front control
- Electronic touch control
- 9 power levels
- Booster function on all zones
- 99 minute timer
- Pause/restart function
- Keep warm function
- Easy clean surface
- Ceramic shatterproof safety glass
- Overheat detection
- Overflow detection
- Automatic pan detection
- Small object detection
- LED display
- Safety key lock
- Auto safety switch off
- Time limit security system
- Temperature limiter

### Available in

- Frameless



### Technical specification

#### Zones:

- Front left, 220mm: 2.3kW, 3kW with booster
- Centre left, 180mm: 1.2kW, 1.4kW with booster
- Centre right, 180mm: 1.2kW, 1.4kW with booster
- Front right, 220mm: 2.3kW, 3kW with booster
- Rated electrical power: 7.4kW
- Power supply required: 32A

### Fitting notes

- Please ensure that you check that there is sufficient clearance when fitting the induction hobs over both single and built-under double ovens and that adequate ventilation is provided.



## Co-ordinating products

This hob matches the 3D9 and EDD91 downdraft extractors.

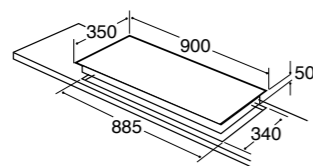

## HNG7410 Four zone induction hob with single gas wok burner

### Features

- Bevelled edges
- Front control
- Induction and gas combination
- 9 power levels
- Booster function (on 2 induction zones)
- 99 minute timer
- Automatic cooking function (induction zones)
- Automatic electronic touch control gas ignition
- Cast iron pan supports
- Residual heat indicators
- Overheat detection
- Overflow detection
- Auto safety switch off
- Wok burner
- Flame failure included

### Accessories

- Wok support (not shown)

### Available in

- Frameless

### Technical specification

#### Burners/zones:

- Left middle, dual wok: 5kW (gas)
- Middle rear, 215mm: 2.3kW, 3kW with booster
- Middle front, 175mm: 1.4kW
- Rear right, 175mm: 1.4kW
- Front right, 215mm: 2.3kW, 3kW with booster
- Rated gas input: 5kW
- Rated electrical power: 7.4kW
- Power supply required: 32A

### Please note

- This hob is supplied in natural gas only.

### Fitting note

- Please ensure that you check that there is sufficient clearance when fitting induction hobs over both single and built-under double ovens and that adequate ventilation is provided.



Bevelled glass edges

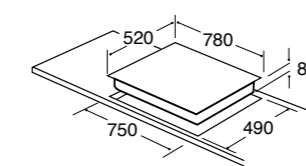

*Keep your kitchen smelling fresh and clean with one of our stylish extractors.*

# Extractors

As well as keeping your kitchen fresh, a stylish CDA extractor will provide a focal point, adding impact to the overall design.



## Automatic cut-off timer

The residual smells of cooking can leave a bad taste in the mouth and they don't stop being produced when the hob is switched off. That's why many touch control models offer an automatic cut-off timer to continue working until the residual steam and odours are removed from your home.



## Filter maintenance

A helpful saturated filter warning light lets you know when the dishwasher grease filters require cleaning, or the charcoal filters need replacing. Maintaining the filters allows your extractor to work safely at its best. By keeping your extractor running efficiently, you'll keep your energy bills in check and your home smelling great.



## Ducted/re-circulating

Choose between ducting your extractor outside or recirculating filtered, cleaned air back into your kitchen with the CDA extractor range. We provide a comprehensive range of ducting kits and charcoal filters, listed on our accessories pages, to support your preference.



## Peripheral aspiration

As well as giving the extractor a minimalist look, peripheral aspiration technology works to draw the air around the edges of the extractor instead of across the whole surface area. This means an ultra-efficient, quieter extractor that's also easy to keep clean.



## Lighting

Powerful lights provide bright and clear illumination when cooking. Several models feature low energy LED downlights and also ambient lighting to make a visual statement of the extractor in your kitchen.

# Quick guide to extractors

Our extensive range of extractors includes integrated and under canopy models, together with a great selection of stylish, contemporary chimney and island extractors for a chic design statement in your kitchen.

Most CDA extractor models have dishwasher aluminium grease filters.

## Extraction and noise level measurements

The extraction rate and noise level measurements are displayed in accordance with EN61591 for extraction rates and EN60704 for noise levels. These measurements provide an approximation of real world performance when installed with recommended ducting kits.

## Required distance between hob and extractor

Please refer to both your hob and extractor instructions before installation - for legal requirements, the distance between your hob and extractor should be determined by the maximum measurement provided.

## Ducting advice

Using ducting of smaller diameter than that recommended may increase the noise level and can reduce the efficiency of your extractor. Where possible, always use the largest diameter ducting you can.

## Functional



### CST61

- Standard extractor
- Available in stainless steel or white
- More details on p90



### EIN60

- Integrated extractor
- Available with acrylic or aluminium grease filters
- More details on p90



### CCA5/7

- Under canopy extractor
- 50cm and 70cm wide
- More details on p91

## Functional



### CTE6

- Telescopic extractor
- 60cm wide
- More details on p91

## Contemporary



### ECH61/71/91/101

- Chimney extractor
- 60cm, 70cm, 90cm and 100cm wide
- Available in stainless steel or black
- More details on p92



### ECHK90

- Chimney island extractor
- 90cm wide
- More details on p92



### ECP62/72/82/92/102/112

- Curved glass extractor
- 60cm, 70cm, 80cm, 90cm, 100cm and 110cm wide
- Available in stainless steel or black
- More details on p93

## Contemporary



### EKP60/70/90

- Curved glass extractor
- 60cm, 70cm and 90cm wide with edge lighting
- Available in stainless steel or black
- More details on p94



### ECPK90

- Curved glass island extractor
- 90cm wide
- More details on p93



### ECN62/72/92

- Flat glass extractor
- 60cm, 70cm and 90cm wide
- More details on p95



### EVPC9

- Corner chimney extractor
- More details on p95

## Angled



### ECA60

- Angled extractor
- 60cm wide
- More details on p98



### EVA60/70/90

- Angled extractor
- 60cm, 70cm and 90cm wide
- More details on p98



### EVG6/9

- Designer extractor
- 60cm and 90cm wide
- Available in stainless steel or black
- More details on p99

## Linear



### EVP61/91/101/121

- Linear extractor
- 60cm, 90cm, 100cm and 120cm wide
- More details on p96



### EVPK90

- Linear island extractor
- 90cm wide
- More details on p97



### EVC4

- Cylinder extractor
- Available in stainless steel or black
- More details on p101



### EVCK4

- Cylinder island extractor
- Available in stainless steel or black
- More details on p101

## Cylinder

## Designer



### EVM9

- Geometric extractor
- More details on p100



### EVQ7

- Q-style designer extractor
- More details on p102



### 3U10

- Updraft extractor
- More details on p103

## Designer



### EVX101

- Ceiling extractor
- Remote control
- More details on p104



### 3S10

- Spherical extractor
- Remote control
- Available in white or black
- More details on p105



### EDD61/91

- Downdraft extractor
- Synchronised sliding system
- More details on p106



### 3D9

- Downdraft extractor
- Synchronised sliding system
- More details on p107

### CST61 Standard extractor



Stainless steel



White

#### Features

- Ducted/re-circulating installation
- 3 speeds
- Push button control
- Aluminium grease filter
- 1 x 28W halogen light
- Glass light diffuser

#### Optional accessories

- Ducting kit, AED51/53/54
- Charcoal filter for re-circulation, CHA5 (pack of 1)

#### Available in

- Stainless steel
- White

#### Technical specification

- Required height over gas hob: 700mm (min)
- Required height over electric hob: 600mm (min)
- Outlet diameter: 120mm
- Noise level: 65dBA
- Extraction rate: 190m<sup>3</sup>/h
- Rated electrical power: 123W
- Power supply: 3A

#### Energy efficiency rating

- Energy rating: D

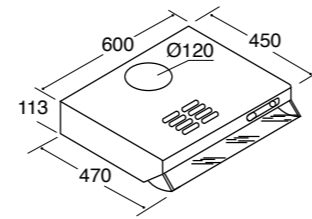

### EIN60 Integrated extractor

#### Features

- Ducted/re-circulating installation
- 3 speeds
- Slider control
- 1 x 28W halogen light

#### Optional accessories

- Ducting kit, AED51/53/54
- Charcoal filter for re-circulation, CHA15 (pack of 1)
- Aluminium grease filter, GRE3M
- Acrylic grease filter, GRE1

#### Available in

- Silver
- Silver - with aluminium grease filter, EIN60FSI

#### Technical specification

- Required height over gas hob: 700mm (min)
- Required height over electric hob: 600mm (min)
- Outlet diameter: 120mm
- Noise level: 62dBA
- Extraction rate:
  - EIN60: 197m<sup>3</sup>/h
  - EIN60FSI: 203m<sup>3</sup>/h
- Rated electrical power: 148W
- Power supply: 3A

#### Energy efficiency rating

- Energy rating: D

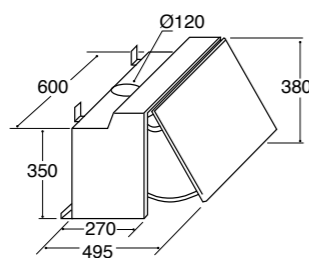
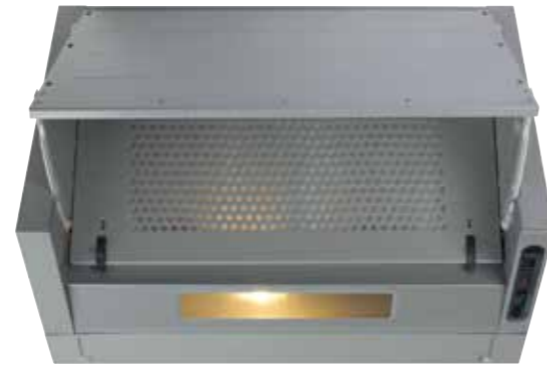

### CCA5/7 Canopy extractor



CCA7 - 70cm wide



CCA5 - 50cm wide

#### Features

- Ducted/re-circulating installation
- 3 speeds
- Slider control
- CCA5 – acrylic grease filter
- CCA7 – aluminium grease filter
- 1 x 28W halogen light (CCA5)
- 2 x 28W halogen lights (CCA7)
- Glass light diffuser

#### Optional accessories

- Ducting kit, AED51/53/54
- Charcoal filter for re-circulation - CHA1 (pack of 1)
- CCA5, Aluminium grease filter, GRE2M
- CCA5, Acrylic grease filter, GRE1

#### Available in

- CCA5 – silver or white
- CCA7 – silver

#### Technical specification

- Required height over gas hob: 700mm (min)
- Required height over electric hob: 600mm (min)
- Outlet diameter: 120mm
- Noise level:
  - CCA5: 65dBA
  - CCA7: 73dBA
- Extraction rate:
  - CCA5: 195m<sup>3</sup>/h
  - CCA7: 313m<sup>3</sup>/h
- Rated electrical power:
  - CCA5: 128W
  - CCA7: 256W
- Power supply: 3A

#### Energy efficiency rating

- Energy rating:
  - CCA5: D
  - CCA7: E

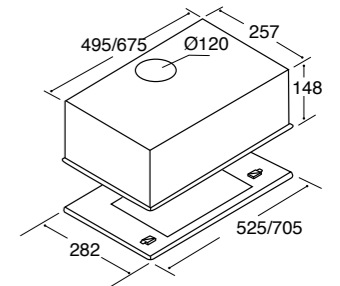

### CTE6 Telescopic extractor

#### Features

- Ducted/re-circulating installation
- 3 speeds
- Slider control
- Aluminium grease filters
- 2 x 28W halogen lights
- Glass light diffuser

#### Optional accessories

- Ducting kit, AED51/53/54
- Charcoal filter for re-circulation, CHA1 (pack of 1)

#### Available in

- Stainless steel

#### Technical specification

- Required height over gas hob: 700mm (min)
- Required height over electric hob: 600mm (min)
- Outlet diameter: 120mm
- Noise level: 65dBA
- Extraction rate: 195m<sup>3</sup>/h
- Rated electrical power: 156W
- Power supply: 3A

#### Energy efficiency rating

- Energy rating: E

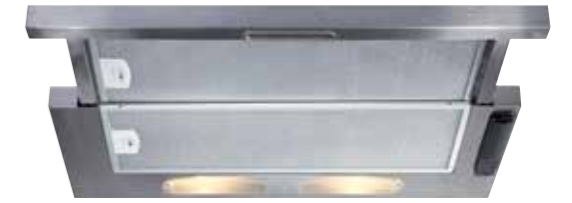

Open



Closed

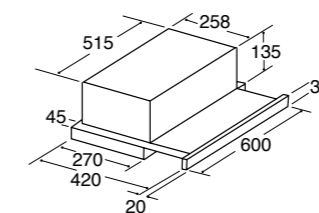

## ECH61/71/91/101 Chimney extractor



ECH91 - stainless steel



ECH61 - black

ECH61 - 60cm wide  
ECH71 - 70cm wide  
ECH91 - 90cm wide  
ECH101 - 100cm wide

### Features

- Ducted/re-circulating installation
- 3 speeds
- Push button control
- Aluminium grease filters
- 2 x 50W halogen lights
- Twin fan motor

### Optional accessories

- Ducting kit, AED61/63/64
- Charcoal filter for re-circulation, CHA24 (pack of 2)

### Available in

- Stainless steel
- Black

### Technical specification

- Required height over gas hob: 700mm (min)
- Required height over electric hob: 600mm (min)
- Outlet diameter: 150mm
- Noise level: 64dBA
- Extraction rate: 427m<sup>3</sup>/h
- Rated electrical power: 240W
- Power supply: 3A

### Energy efficiency rating

- Energy rating: E

### Fitting note

- Please ensure that you check the ceiling height is sufficient to allow the required clearance between the hob and extractor.

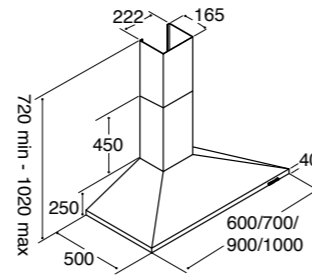

## ECHK90 Chimney island extractor

- Features**
- Ducted/re-circulating installation
  - 3 speeds
  - Push button control
  - Aluminium grease filters
  - 2 x 2W LED lights
- Optional accessories**
- Ducting kits
    - 120mm, AED51/53/54
    - 150mm, AED61/63/64
  - Charcoal filter for re-circulation, CHA25 (pack of 2)

- Available in**
- Stainless steel

- Technical specification**
- Required height over gas hob: 700mm (min)
  - Required height over electric hob: 600mm (min)
  - Outlet diameter: 120mm/150mm
  - Noise level: 61dBA
  - Extraction rate: 404m<sup>3</sup>/h
  - Rated electrical power: 104W
  - Power supply: 3A

### Energy efficiency rating

- Energy rating: D

### Fitting note

- Please ensure that you check the ceiling height is sufficient to allow the required clearance between the hob and extractor.

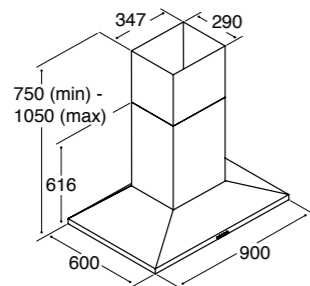

## ECP62/72/82/92/102/112 Curved glass extractor



ECP62 - stainless steel



ECP92 - black

ECP62 - 60cm wide  
ECP72 - 70cm wide  
ECP82 - 80cm wide  
ECP92 - 90cm wide  
ECP102 - 100cm wide  
ECP112 - 110cm wide

The black ECP models have a smoked glass canopy

### Features

- Ducted/re-circulating installation
- 3 speeds
- Push button control
- Aluminium grease filters
- 2 x 2W LED lights

### Optional accessories

- Ducting kits
  - 120mm, AED51/53/54
  - 150mm, AED61/63/64
- Charcoal filter for re-circulation, CHA12 (pack of 1)

### Available in

- Stainless steel
- Black

### Technical specification

- Required height over gas hob: 700mm (min)
- Required height over electric hob: 600mm (min)
- Outlet diameter: 120mm/150mm
- Noise level: 60dBA
- Extraction rate:
  - ECP62/72/82: 391m<sup>3</sup>/h
  - ECP92/102/112: 377m<sup>3</sup>/h
- Rated electrical power: 104W
- Power supply: 3A

### Energy efficiency rating

- Energy rating: D

### Fitting note

- Please ensure that you check the ceiling height is sufficient to allow the required clearance between the hob and extractor.

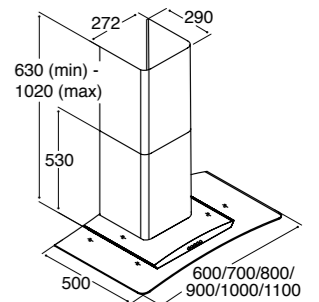

## ECPK90 Curved glass island extractor

- Features**
- Ducted/re-circulating installation
  - 3 speeds
  - Push button control
  - Aluminium grease filters
  - 4 x 2W LED lights
- Optional accessories**
- Ducting kits
    - 120mm, AED51/53/54
    - 150mm, AED61/63/64
  - Charcoal filter for re-circulation, CHA25 (pack of 2)

- Available in**
- Stainless steel

- Technical specification**
- Required height over gas hob: 700mm (min)
  - Required height over electric hob: 600mm (min)
  - Outlet diameter: 120mm/150mm
  - Noise level: 61dBA
  - Extraction rate: 387m<sup>3</sup>/h
  - Rated electrical power: 108W
  - Power supply: 3A

### Energy efficiency rating

- Energy rating: E

### Fitting note

- Please ensure that you check the ceiling height is sufficient to allow the required clearance between the hob and extractor.

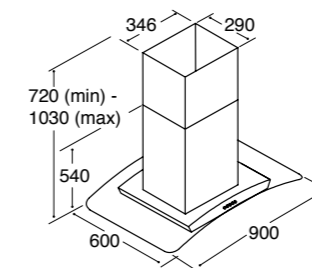

See page 209 for our matching square and curved glass splashbacks.

**LED lighting**  
 As well as superb performance, the EKP range of extractors offers an extra aesthetic detail with edge lighting to make a real focal point in your kitchen.

**EKP60/70/90 Curved glass extractor with edge lighting**



EKP60 - 60cm wide  
 EKP70 - 70cm wide  
 EKP90 - 90cm wide

EKP60 - stainless steel



Choose from red, blue or green lighting

EKP90 - black



Red lighting



Blue lighting

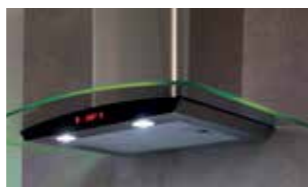

Green lighting

- Features**
- Ducted/re-circulating installation
  - 3 speeds
  - Touch control
  - Aluminium grease filters
  - 2 x 3W LED lights
  - 3W of edge lighting
  - 9 minute timer
- Optional accessories**
- Ducting kits - 120mm, AED51/53/54 - 150mm, AED61/63/64
  - Charcoal filter for re-circulation, CHA17 (pack of 2)
- Available in**
- Stainless steel
  - Black

- Technical specification**
- Required height over gas hob: 700mm (min)
  - Required height over electric hob: 600mm (min)
  - Outlet diameter: 120mm
  - Noise level: 69dBA
  - Extraction rate: 336m<sup>3</sup>/h
  - Rated electrical power: 129W
  - Power supply: 3A

- Energy efficiency rating**
- Energy rating: D
- Fitting note**
- Please ensure that you check the ceiling height is sufficient to allow the required clearance between the hob and extractor.

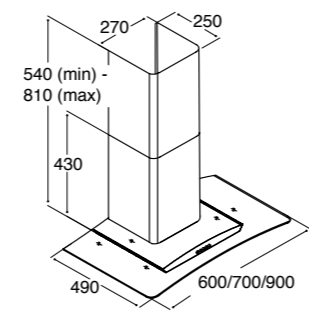

**ECN62/72/92 Flat glass extractor**



ECN62 - 60cm wide  
 ECN72 - 70cm wide  
 ECN92 - 90cm wide

ECN62



ECN92

- Features**
- Ducted/re-circulating installation
  - 3 speeds
  - Push button control
  - Aluminium grease filter
  - 2 x 2W LED lights
- Optional accessories**
- Ducting kits - 120mm, AED51/53/54 - 150mm, AED61/63/64
  - Charcoal filter for re-circulation, CHA12 (pack of 1)

- Available in**
- Stainless steel

- Technical specification**
- Required height over gas hob: 700mm (min)
  - Required height over electric hob: 600mm (min)
  - Outlet diameter: 120mm/150mm
  - Noise level: 60dBA
  - Extraction rate: 391m<sup>3</sup>/h
  - Rated electrical power: 104W
  - Power supply required: 3A

- Energy efficiency rating**
- Energy rating: D

- Fitting note**
- Please ensure that you check the ceiling height is sufficient to allow the required clearance between the hob and extractor.

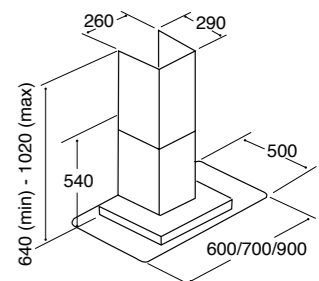

**EVPC9 Corner extractor**

- Features**
- Ducted/re-circulating installation
  - 3 speeds + intensive
  - Touch control
  - Aluminium grease filters
  - 3 x 20W halogen lights
  - Twin fan motor
  - Filter saturation warning light
  - Clean air function
  - 15 minute timer
- Optional accessories**
- Ducting kit, AED61/63/64
  - Charcoal filter for re-circulation, CHA2 (pack of 2)
- Available in**
- Stainless steel

- Technical specification**
- Required height over gas hob: 650mm (min)
  - Required height over electric hob: 650mm (min)
  - Outlet diameter: 150mm
  - Noise level: 64dBA
  - Extraction rate: 520m<sup>3</sup>/h
  - Rated electrical power: 310W
  - Power supply: 3A

- Energy efficiency rating**
- Energy rating: D

- Fitting note**
- Please ensure that you check the ceiling height is sufficient to allow the required clearance between the hob and extractor.

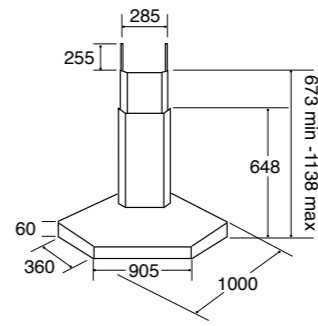



**EVP61/91/101/121** Linear extractor



EVP61 - 60cm wide  
EVP91 - 90cm wide  
EVP101 - 100cm wide  
EVP121 - 120cm wide

- Features**
- Ducted/re-circulating installation
  - 3 speeds + intensive
  - Touch control
  - Aluminium grease filters
  - 2 x 20W halogen lights
  - Twin fan motor
  - Filter saturation warning light
  - Clean air function
  - 15 minute timer
- Optional accessories**
- Ducting kit, AED61/63/64
  - Charcoal filter for re-circulation, CHA21 (pack of 2)
- Available in**
- Stainless steel

- Technical specification**
- Required height over gas hob: 700mm (min)
  - Required height over electric hob: 600mm (min)
  - Outlet diameter: 150mm
  - Noise level: 62dBA
  - Extraction rate: 503m³/h
  - Rated electrical power: 290W
  - Power supply required: 3A
- Energy efficiency rating**
- Energy rating: D
- Fitting note**
- Please ensure that you check the ceiling height is sufficient to allow the required clearance between the hob and extractor.

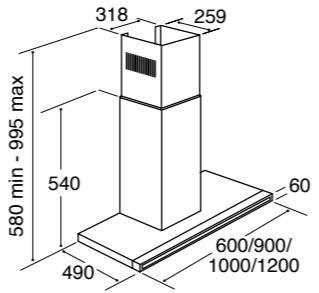

**EVPK90** Linear island extractor



- Features**
- Ducted/re-circulating installation
  - 3 speeds + intensive
  - Touch control
  - Aluminium grease filters
  - 4 x 20W halogen lights
  - Twin fan motor
  - Filter saturation warning light
  - Clean air function
  - 15 minute timer
- Optional accessories**
- Ducting kit, AED61/63/64
  - Charcoal filter for re-circulation, CHA21 (pack of 2)
- Available in**
- Stainless steel

- Technical specification**
- Required height over gas hob: 700mm (min)
  - Required height over electric hob: 600mm (min)
  - Outlet diameter: 150mm
  - Noise level: 64dBA
  - Extraction rate: 520m³/h
  - Rated electrical power: 330W
  - Power supply required: 3A
- Energy efficiency rating**
- Energy rating: D
- Fitting note**
- Please ensure that you check the ceiling height is sufficient to allow the required clearance between the hob and extractor.

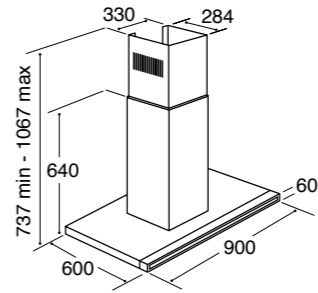

### ECA60 Angled extractor



#### Features

- Ducted/re-circulating installation
- 3 speeds
- Push button control
- Aluminium grease filter
- 2 x 2W LED lights
- Twin fan motor

#### Optional accessories

- Ducting kit, AED51/53/54
- Charcoal filter for re-circulation, CHA15 (pack of 1)

#### Available in

- Black

#### Technical specification

- Required height over gas hob: 550mm (min)
- Required height over electric hob: 550mm (min)
- Outlet diameter: 120mm
- Noise level: 64dBA
- Extraction rate: 350m<sup>3</sup>/h
- Rated electrical power: 114W
- Power supply: 3A

#### Energy efficiency rating

- Energy rating: B

#### Fitting note

- Please ensure that you check the ceiling height is sufficient to allow the required clearance between the hob and extractor.

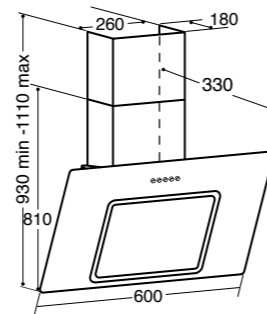

### EVA60/70/90 Angled extractor



EVA60 - 60cm wide  
EVA70 - 70cm wide  
EVA90 - 90cm wide

#### Features

- Ducted/re-circulating installation
- 3 speeds
- Touch control
- Aluminium grease filter
- 2 x 2W LED lights
- Twin fan motor
- 15 minute timer

#### Optional accessories

- Ducting kit, AED51/53/54
- Charcoal filter for re-circulation, CHA15 (pack of 1)

#### Available in

- Black

#### Technical specification

- Required height over gas hob: 550mm (min)
- Required height over electric hob: 550mm (min)
- Outlet diameter: 120mm
- Noise level: 64dBA
- Extraction rate: 350m<sup>3</sup>/h
- Rated electrical power: 114W
- Power supply: 3A

#### Energy efficiency rating

- Energy rating: B

#### Fitting note

- Please ensure that you check the ceiling height is sufficient to allow the required clearance between the hob and extractor.

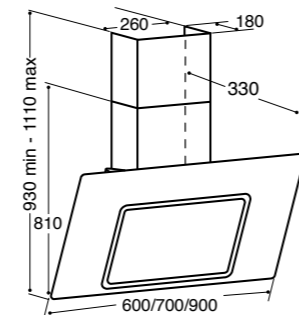

EVA60



EVA90

### EVG6/9 Designer extractor



EVG9 - black

Black glass panel



EVG6 - stainless steel

Clear glass panel

#### Features

- Ducted/re-circulating installation
- 3 speeds + intensive
- Touch control
- Aluminium grease filter
- 2 x 20W halogen lights
- Twin fan motor
- Filter saturation warning light
- Clean air function
- 15 minute timer

#### Optional accessories

- Ducting kit, AED61/63/64
- Charcoal filter for re-circulation, CHA21 (pack of 2)

#### Available in

- Stainless steel
- Black

#### Technical specification

- Required height over CDA gas hob: 450mm (min), otherwise 760mm (min)
- Required height over CDA electric hob: 450mm (min), otherwise 650mm (min)
- Outlet diameter: 150mm
- Noise level: 58dBA
- Extraction rate: 465m<sup>3</sup>/h
- Rated electrical power: 290W
- Power supply required: 3A

#### Energy efficiency rating

- Energy rating: D

#### Fitting note

- Please ensure that you check the ceiling height is sufficient to allow the required clearance between the hob and extractor.



EVG9 halogen lights

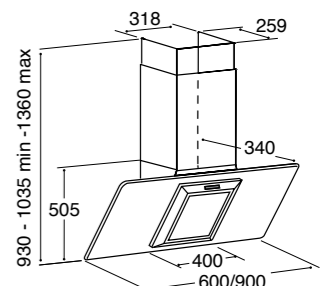

### Clean air function

The clean air function means that your extractor comes on for ten minutes every hour, outside of use during cooking. In these ten minutes the extractor works to purify the air in your kitchen, meaning it is not just a companion for your hob; it even works hard when you are not cooking.

## EVM9 Geometric extractor



Side view

### Features

- Ducted/re-circulating installation
- 3 speeds + intensive
- Touch control
- Aluminium grease filter
- 2 x 20W halogen lights
- Twin fan motor
- Filter saturation warning light
- Clean air function
- 15 minute timer

### Optional accessories

- Ducting kit, AED61/63/64
- Charcoal filter for re-circulation, CHA2 (pack of 2)
- Chimney section, AEV01SS

### Available in

- Stainless steel with black glass fascia.



View from below

### Technical specification

- Required height over CDA gas hob: 450mm (min), otherwise 760mm (min)
- Required height over CDA electric hob: 450mm (min), otherwise 650mm (min)
- Outlet diameter: 150mm
- Noise level: 64dBA
- Extraction rate: 478m<sup>3</sup>/h
- Rated electrical power: 290W
- Power supply required: 3A

### Energy efficiency rating

- Energy rating: D

### Fitting note

- Please ensure that you check the ceiling height is sufficient to allow the required clearance between the hob and extractor.

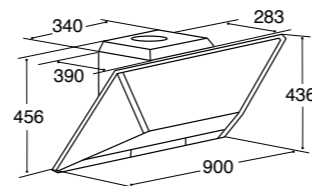

## EVC4 Cylinder extractor



Black



Stainless steel (side view)

### Features

- Ducted/re-circulating installation
- 3 speeds + intensive
- Soft touch buttons
- Aluminium grease filter
- 2 x 20W halogen lights
- Filter saturation warning light
- Clean air function
- 15 minute timer
- Peripheral aspiration

### Optional accessories

- Ducting kit, AED61/63/64
- Charcoal filter for re-circulation, CHA2 (pack of 2)

### Available in

- Stainless steel
- Black

### Technical specification

- Required height over gas hob: 650mm (min)
- Required height over electric hob: 650mm (min)
- Outlet diameter: 150mm
- Noise level: 62dBA
- Extraction rate: 503m<sup>3</sup>/h
- Rated electrical power: 290W
- Power supply: 3A

### Energy efficiency rating

- Energy rating: D

### Fitting note

- Please ensure that you check the ceiling height is sufficient to allow the required clearance between the hob and extractor.

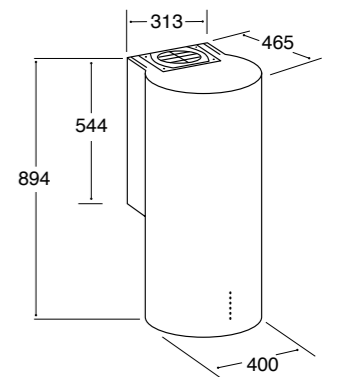

## EVCK4 Cylinder island extractor



Stainless steel



Black

### Features

- Ducted/re-circulating installation
- 3 speeds + intensive
- Soft touch buttons
- Aluminium grease filter
- 2 x 20W halogen lights
- Filter saturation warning light
- Clean air function
- 15 minute timer
- Peripheral aspiration

### Optional accessories

- Ducting kit, AED61/63/64
- Charcoal filter for re-circulation, CHA2 (pack of 2)

### Available in

- Stainless steel
- Black

### Technical specification

- Required height over gas hob: 650mm (min)
- Required height over electric hob: 650mm (min)
- Outlet diameter: 150mm
- Noise level: 62dBA
- Extraction rate: 503m<sup>3</sup>/h
- Rated electrical power: 290W
- Power supply: 3A

### Energy efficiency rating

- Energy rating: D

### Fitting note

- Please ensure that you check the ceiling height is sufficient to allow the required clearance between the hob and extractor.

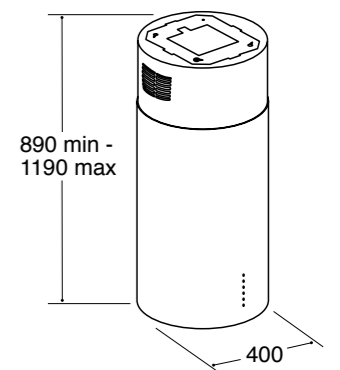

**EVQ7** Circular extractor



Features

- Ducted/re-circulating installation
- 3 speeds + intensive
- Touch control
- Aluminium grease filter
- 2 x 20W halogen lights
- 99 minute variable timer
- Quick start

Optional accessories

- Ducting kit, AED61/63/64
- Charcoal filter for re-circulation, CHA16 (pack of 1)

Available in

- Stainless steel with black glass fascia

Technical specification

- Required height over gas hob: 650mm (min)
- Required height over electric hob: 650mm (min)
- Outlet diameter: 150mm
- Noise level: 71dBA
- Extraction rate: 393m<sup>3</sup>/h
- Rated electrical power: 238W
- Power supply required: 3A

Energy efficiency rating

- Energy rating: D

Fitting note

- Please ensure that you check the ceiling height is sufficient to allow the required clearance between the hob and extractor.

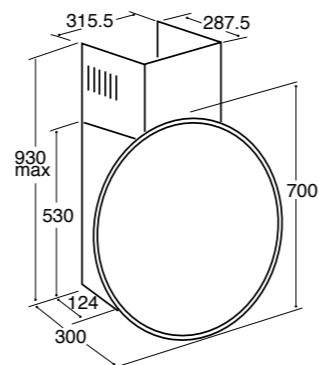

Co-ordinating products

This extractor matches the 6Q5 single oven, 9Q5 double oven, 4Q4 hob and 4Q5 hob.

**3U10** Updraft extractor



Features

- Ducted/re-circulating installation
- 3 speeds + intensive
- Touch control
- Aluminium grease filter
- 1 x 10W LED strip light
- Filter saturation warning light
- 10 minute timer

Optional accessories

- Ducting kit, AED61/63/64
- Charcoal filter for re-circulation, CHA32 (pack of 2)

Available in

- Stainless steel with black glass fascia.

Technical specification

- Required height over gas hob: 650mm (min)
- Required height over electric hob: 650mm (min)
- Outlet diameter: 150mm
- Noise level: 68dBA
- Extraction rate: 496m<sup>3</sup>/h
- Rated electrical power: 90W
- Power supply required: 3A

Energy efficiency rating

- Energy rating: C

Fitting note

- Please ensure that you check the ceiling height is sufficient to allow the required clearance between the hob and extractor.



View from below

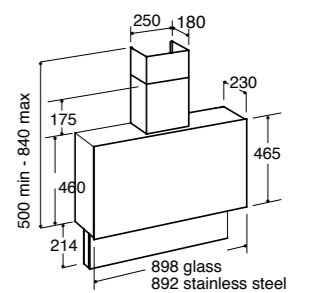

**Focal point**  
 The 3S10 in black has crisp LED downlighting to illuminate your cooking space whilst the 3S10 in white provides an ambient glow with internal neon lights.

**EVX101 Ceiling extractor**



- Features**
- Ducted/re-circulating installation
  - 8 speeds + intensive
  - Soft touch buttons
  - Stainless steel grease filters
  - 4 x 4W LED lights
  - Filter saturation warning light
  - Clean air function
  - 30 minute timer
  - Peripheral aspiration
- Accessories**
- Remote control
- Optional accessories**
- Ducting kit, AED61/63/64
  - Charcoal filter for re-circulation, CHA18 (pack of 2)
- Available in**
- Stainless steel
- Technical specification**
- Required height over gas hob: 750mm (min)
  - Required height over electric hob: 750mm (min)
  - Outlet diameter: 150mm
  - Noise level: 64dBA
  - Extraction rate: 570m<sup>3</sup>/h
  - Rated electrical power: 286W
  - Power supply required: 3A
- Energy efficiency rating**
- Energy rating: B
- Fitting notes**
- The extraction outlet can be rotated through 90°, 180° or 270°, allowing for flexible installation.



Remote control

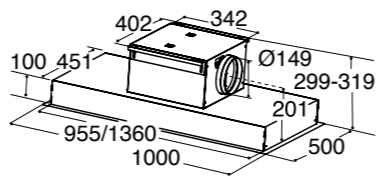

**3S10 Spherical designer extractor**



Black



White



Remote control



3S10BL, elevated view

- Features**
- Re-circulating installation
  - 3 speeds + intensive
  - Aluminium grease filter
  - 3S10BL - 1 x 3W LED downlight
  - 3S10WH - 2 x 40W neon lights
  - 10 minute timer
- Accessories**
- Remote control
  - Charcoal filter for re-circulation, CHA30 (pack of 2)
- Available in**
- White
  - Black
- Technical specification**
- Required height over gas hob: 650mm (min)
  - Required height over electric hob: 650mm (min)
  - Noise level: 48dBA
  - Extraction rate: 320m<sup>3</sup>/h
  - Rated electrical power: - 143W (3S10BL) - 220W (3S10WH)
  - Power supply required: 3A
- Fitting notes**
- Please ensure that you check the ceiling height is sufficient to allow the required clearance between the hob and extractor.

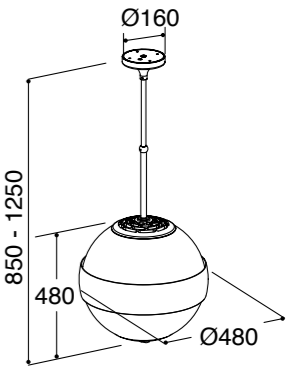

**Downdraft extractors**  
 Sleek and efficient, downdraft extractors slip effortlessly away below the worktop when not in use - the perfect choice for a minimalist, modern kitchen, or for a room where a low ceiling height limits the use of an overhead extractor.

**EDD61/91 Downdraft extractor**



EDD91 - black



EDD61 - black

EDD61 - 60cm wide  
 EDD91 - 90cm wide

**Features**

- Ducted/re-circulating installation
- EDD61: 4 speeds
- EDD91: 3 speeds + intensive
- Touch control
- Aluminium grease filters
- 10 minute timer
- Synchronised sliding system
- Glass control panel
- Motor included

**Optional accessories**

- Ducting kit, AED61/63/64
- Charcoal filter for recirculation
  - EDD61, CHA19 (pack of 2)
  - EDD91, CHA11 (pack of 2)

**Available in**

- Black

**Technical specification**

- Outlet diameter: 150mm
- Noise level:
  - EDD61: 69dBA
  - EDD91: 61dBA
- Extraction rate:
  - EDD61: 636m<sup>3</sup>/h
  - EDD91: 605m<sup>3</sup>/h
- Rated electrical power: 275W
- Power supply required: 3A

**Energy efficiency rating**

- Energy rating:
  - EDD61: A
  - EDD91: A+

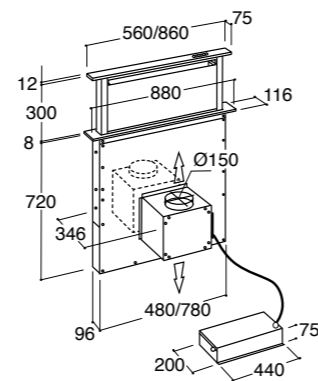

**Co-ordinating products**

The EDD91 extractor matches any of our linear hobs.

**3D9 Downdraft extractor**



**Features**

- Ducted/re-circulating installation
- 4 speeds
- Touch control
- Aluminium grease filters
- 1 x 14W neon light
- 10 minute timer
- Synchronised sliding system
- Glass control panel and side panel
- Motor included

**Optional accessories**

- Ducting kit, AED61/63/64
- Charcoal filter for re-circulation, CHA14 (pack of 2)

**Available in**

- Black



Closed

**Technical specification**

- Outlet diameter: 150mm
- Noise level: 68dBA
- Extraction rate: 757m<sup>3</sup>/h
- Rated electrical power: 289W
- Power supply required: 3A

**Energy efficiency rating**

- Energy rating: A

**Co-ordinating products**

This extractor matches any of our linear hobs.

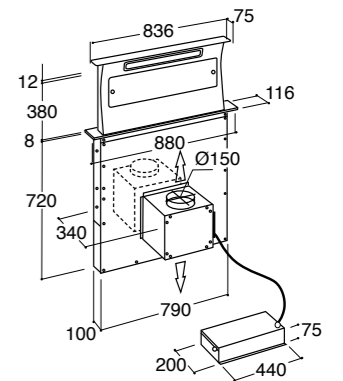

# Cooling

Our refrigeration range includes everything from American style fridge freezers to under counter fridges, all carefully designed to keep your food under optimum conditions.



*Our fridge freezers are available in a combination of configurations, finishes and hinge options offering the perfect centrepiece for any kitchen.*

## A+ energy efficiency

We are committed to reducing our impact on the environment which is why our entire refrigeration range is at least A+ rated for energy efficiency. A+ rated products use up to 25% less energy than A rated models, meaning lower running costs.



## 4 star freezers

All CDA freezers come with a 4 star rating, the highest classification available. A 4 star rating allows you to store frozen food for up to 12 months and freeze fresh food efficiently and safely.

## LED interior lighting

This eye-catching feature will delight you as soon as you open the door. The LED lights emit no heat and run on very little energy. Plus, the beautifully designed PC900 American style premium frost free four door fridge freezer is bright enough to cast light into every corner of the fridge.



## Draught beer dispenser

This unique compact appliance can serve a beautiful pub-style pint of beer or lager in your own kitchen! The professional beer connection kit is pre-assembled on a steel plate ready for positioning below the dispenser. The beer passes through the integral flash chiller before it is dispensed at your preferred temperature.

# Quick guide to refrigeration

The CDA refrigeration range includes both integrated and freestanding options.

Integrated models offer a variety of fridge, freezer and combination options to suit your kitchen.

The freestanding range includes the superb American style side-by-sides, under counters, combination fridge freezers and a range of wine coolers.

All CDA fridges have an automatic self-defrosting feature so you never have to spend time defrosting your fridge.

## Integrated refrigeration



**FW223**

- Under counter larder fridge
- Energy rating: A+
- More details on p112



**FW253**

- Under counter fridge with ice box
- Energy rating: A+
- More details on p112



**FW283**

- Under counter freezer
- Energy rating: A+
- More details on p112

## Integrated refrigeration



**FW321**

- Under counter larder fridge
- Energy rating: A+
- More details on p113



**FW381**

- Under counter freezer
- Energy rating: A+
- More details on p113



**FW422**

- In-column larder fridge
- Energy rating: A+
- More details on p113



**FW482**

- In-column freezer
- Energy rating: A+
- More details on p114

## Integrated refrigeration



**FW522**

- Three-quarter height larder fridge
- Energy rating: A+
- More details on p114



**FW582**

- Three-quarter height freezer
- Energy rating: A+
- More details on p114



**FW821**

- Full height fridge
- Energy rating: A+
- More details on p115

## Integrated refrigeration



**FW881**

- Full height freezer
- Energy rating: A+
- More details on p115



**FW852**

- 50/50 fridge/freezer
- Energy rating: A+
- More details on p116



**FW872**

- 70/30 fridge/freezer
- Energy rating: A+
- More details on p116



**FW951**

- 50/50 frost free fridge/freezer
- Energy rating: A+
- More details on p117



**FW971**

- 70/30 frost free fridge/freezer
- Energy rating: A+
- More details on p117

## Freestanding refrigeration



**FF121**

- 54cm under counter larder fridge
- Energy rating: A+
- More details on p118



**FF151**

- 54cm under counter fridge with ice box
- Energy rating: A+
- More details on p118



**FF181**

- 54cm under counter freezer
- Energy rating: A+
- More details on p119

## Freestanding refrigeration



**FF852**

- Freestanding 50/50 fridge/freezer
- Energy rating: A+
- More details on p119



**FF660**

- Freestanding 60/40 fridge/freezer
- Energy rating: A+
- More details on p120



**FF770**

- Freestanding 70/30 fridge/freezer
- Energy rating: A+
- More details on p121



**FF820**

- Full height larder fridge
- Energy rating: A++
- More details on p123



**FF880**

- Full height freezer
- Energy rating: A++
- More details on p122

## Freestanding refrigeration



**PC52**

- American style side-by-side fridge freezer
- Energy rating: A+
- More details on p124



**PC71**

- American style side-by-side fridge freezer
- Energy rating: A+
- More details on p125



**PC84**

- American style two door fridge with two drawer freezer
- Energy rating: A+
- More details on p126

## Freestanding refrigeration



**PC88**

- American style four door fridge freezer
- Energy rating: A+
- More details on p127



**PC870**

- American style two door fridge with two drawer freezer
- Energy rating: A+
- More details on p128



**PC900**

- American style premium four door fridge freezer
- Energy rating: A+
- More details on p129

## Wine coolers



**Freestanding and integrated**  
See p132-136

## Beer dispenser



**BVB4**  
• Professional fully integrated beer dispenser  
More details on p137



**FW223** Integrated/under counter larder fridge

## Features

- Interior light
- 3 glass shelves
- 1 salad crisper compartment
- 2 in-door balconies
- 1 egg tray

## Technical specification

- Height adjustable feet
- Reversible door
- Fixed hinges
- Total useable capacity: 133L
- Noise level: 44dBA

## Energy efficiency rating

- Energy rating: A+

## Energy consumption

- Energy consumption per annum: 115kW.h

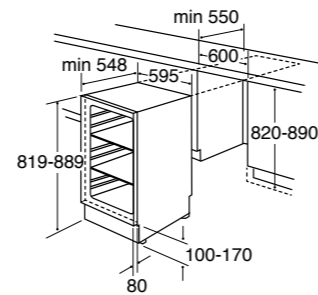
**FW321** Integrated/under counter larder fridge

## Features

- Interior light
- 3 stainless steel edged glass shelves
- 1 salad crisper compartment
- 2 in-door balconies
- 1 egg tray

## Technical specification

- Height adjustable feet
- Reversible door
- Fixed hinges
- Total useable capacity: 133L net
- Noise level: 44dBA

## Energy efficiency rating

- Energy rating: A+

## Energy consumption

- Energy consumption per annum: 115kW.h

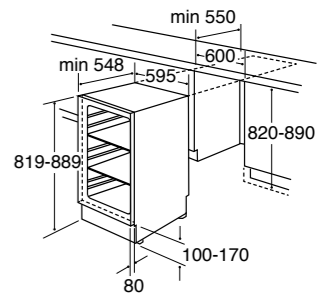
**FW253** Integrated/under counter fridge with ice box

## Features

- Interior light
- 2 glass shelves
- 1 salad crisper compartment
- 2 in-door balconies
- 1 egg tray

## Ice box features

- 4 star rating
- 1 ice cube tray

## Technical specification

- Front adjustable feet
- Reversible door
- Fixed hinges
- Fridge useable capacity: 98L net
- Ice box useable capacity: 17L net
- Freezing capacity: 2kg/24h

- Total useable capacity: 115L net
- Noise level: 44dBA

## Energy efficiency rating

- Energy rating: A+

## Energy consumption

- Energy consumption per annum: 171kW.h

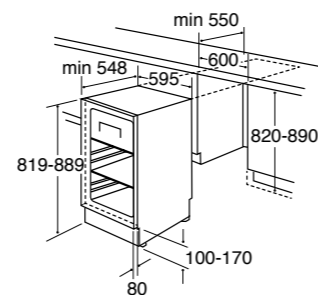
**FW381** Integrated/under counter freezer

## Features

- 4 star rating
- 3 storage compartments
- 1 ice cube tray

## Technical specification

- Height adjustable feet
- Reversible door
- Fixed hinges
- Freezing capacity: 9kg/24h
- Total useable capacity: 93L net
- Noise level: 44dBA

## Energy efficiency rating

- Energy rating: A+

## Energy consumption

- Energy consumption per annum: 177 kW.h

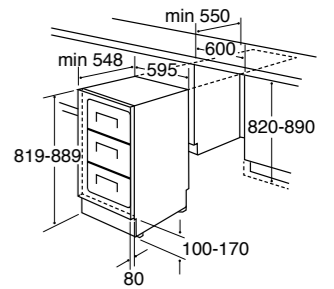
**FW283** Integrated/under counter freezer

## Features

- 4 star rating
- 3 storage compartments
- 1 ice cube tray

## Technical specification

- Height adjustable feet
- Reversible door
- Fixed hinges
- Freezing capacity: 9kg/24h
- Total useable capacity: 93L net
- Noise level: 44dBA

## Energy efficiency rating

- Energy rating: A+

## Energy consumption

- Energy consumption per annum: 177kW.h

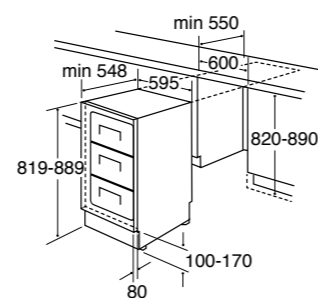
**FW422** Integrated in-column larder fridge

## Features

- Interior light
- 4 glass shelves
- 2 salad crisper drawers
- 3 in-door balconies
- 1 egg tray

## Technical specification

- Reversible door
- Fixed hinges
- Total useable capacity: 134L net
- Noise level: 41dBA

## Energy efficiency rating

- Energy rating: A+

## Energy consumption

- Energy consumption per annum: 121kW.h

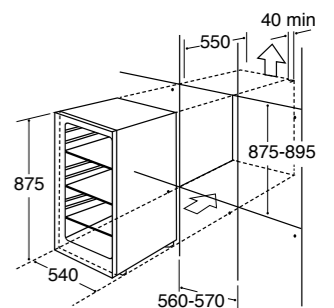

⇨ = airflow

### FW482 Integrated in-column freezer



**Features**

- 4 star rating
- 4 storage compartments
- 1 ice cube tray

**Technical specification**

- Reversible door
- Fixed hinges
- Freezing capacity: 8kg/24h
- Total useable capacity: 99L net
- Noise level: 39dBA

**Energy efficiency rating**

- Energy rating: A+

**Energy consumption**

- Energy consumption per annum: 195kW.h

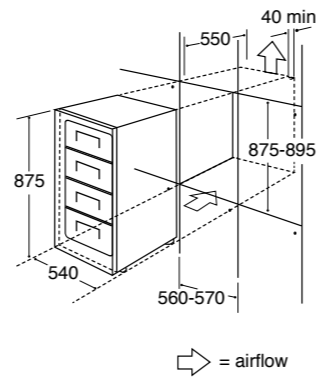

### FW522 Integrated three-quarter height larder fridge



**Features**

- LED interior light
- 5 glass shelves
- 1 salad crisper drawer
- 3 in-door balconies
- 1 egg tray

**Technical specification**

- Height adjustable feet
- Reversible door
- Fixed hinges
- Total useable capacity: 197L
- Noise level: 41dBA

**Energy efficiency rating**

- Energy rating: A+

**Energy consumption**

- Energy consumption per annum: 128kW.h

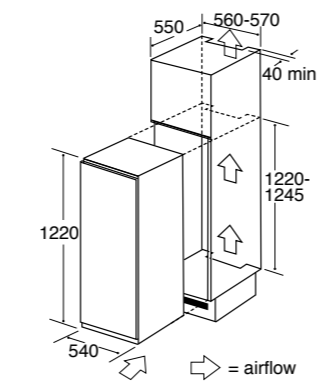

### FW582 Integrated three-quarter height freezer



**Features**

- 4 star rating
- 5 storage drawers
- 1 ice tray
- Fast freeze
- Temperature warning light

**Technical specification**

- Height adjustable feet
- Reversible door
- Fixed hinges
- Freezing capacity: 6.5kg/24h
- Total useable capacity: 130L net
- Noise level: 41dBA

**Energy efficiency rating**

- Energy rating: A+

**Energy consumption**

- Energy consumption per annum: 215kW.h

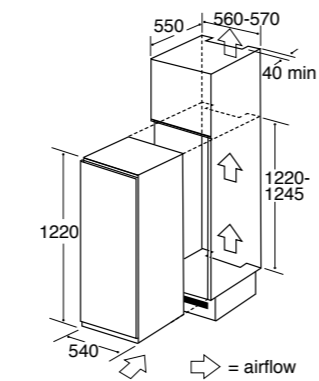

### FW821 Integrated full height larder fridge



**Features**

- LED interior lighting
- 6 glass shelves
- 2 salad crisper drawers
- 5 in-door balconies
- 1 egg tray

**Technical specification**

- Front adjustable feet
- Reversible door
- Sliding furniture fixings
- Total useable capacity: 298L net
- Noise level: 39dBA

**Energy efficiency rating**

- Energy rating: A+

**Energy consumption**

- Energy consumption per annum: 141kW.h

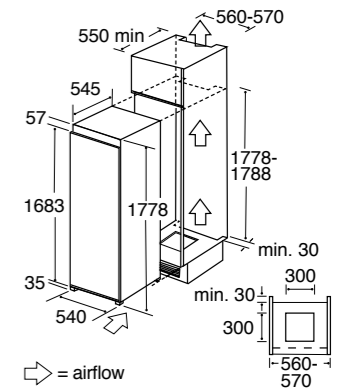

### FW881 Integrated full height freezer

**Features**

- 4 star rating
- Temperature warning light
- Fast freeze
- 9 storage compartments
- 1 ice cube tray

**Technical specification**

- Front adjustable feet
- Reversible door
- Sliding furniture fixings
- Freezing capacity: 10.5kg/24h
- Total useable capacity: 198L net
- Noise level: 39dBA

**Energy efficiency rating**

- Energy rating: A+

**Energy consumption**

- Energy consumption per annum: 258kW.h

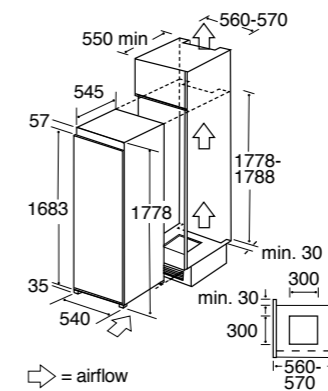

**FW852** Integrated 50/50 combination fridge freezer



Fridge features

- LED interior lighting
- Electronic control
- 3 glass shelves
- 2 salad crisper drawers
- 3 in-door balconies
- 1 egg tray
- Chrome bottle rack

Freezer features

- 4 star rating
- Fast freeze
- 4 storage compartments
- 1 ice cube tray

Technical specification

- Reversible doors
- Sliding furniture fixings
- Fridge useable capacity: 147L net
- Freezer useable capacity: 81L net
- Freezing capacity: 4.5kg/24h
- Total useable capacity: 228L net
- Noise level: 39dBA

Energy efficiency rating

- Energy rating: A+

Energy consumption

- Energy consumption per annum: 263kW.h

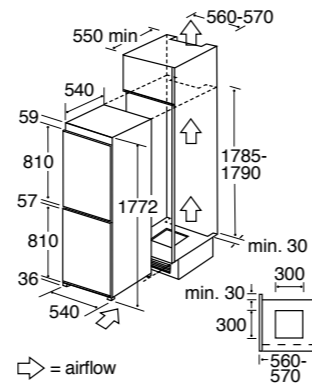

**FW951** Integrated 50/50 combination frost free fridge freezer



Fridge features

- Multi airflow cooling system
- LED interior lighting
- Super cool function
- Door open alarm
- Electronic control
- 4 glass shelves
- 1 variable humidity salad crisper drawer
- 3 in-door balconies
- 2 egg trays

Freezer features

- 4 star rating
- Frost free
- Fast freeze
- 4 storage compartments
- 1 ice cube tray



Technical specification

- Reversible doors
- Fixed hinges
- Fridge useable capacity: 148L net
- Freezer useable capacity: 84L net
- Freezing capacity: 10kg/24h
- Total useable capacity: 232L net
- Noise level: 39dBA

Energy efficiency rating

- Energy rating: A+

Energy consumption

- Energy consumption per annum: 312kW.h

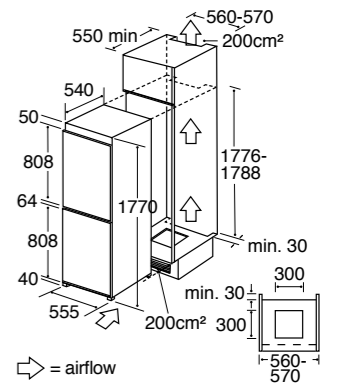

**FW872** Integrated 70/30 combination fridge freezer



Fridge features

- LED interior lighting
- Electronic control
- 4 glass shelves
- 2 salad crisper drawers
- 4 in-door balconies
- 1 egg tray
- Chrome bottle rack

Freezer features

- 4 star rating
- Fast freeze
- 3 storage compartments
- 1 ice cube tray

Technical specification

- Reversible doors
- Sliding furniture fixings
- Fridge useable capacity: 182L net
- Freezer useable capacity: 60L net
- Freezing capacity: 3.5kg/24h
- Total useable capacity: 242L net
- Noise level: 39dBA

Energy efficiency rating

- Energy rating: A+

Energy consumption

- Energy consumption per annum: 260kW.h

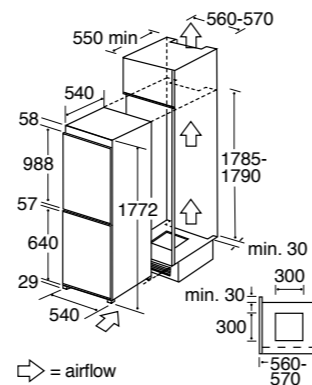

**FW971** Integrated 70/30 combination frost free fridge freezer



Fridge features

- Multi airflow cooling system
- LED interior lighting
- Super cool function
- Door open alarm
- Electronic control
- 5 glass shelves
- 1 variable humidity salad crisper drawer
- 3 in-door balconies
- 2 egg trays

Freezer features

- 4 star rating
- Frost free
- Fast freeze
- 3 storage compartments
- 1 ice cube tray



Technical specification

- Reversible doors
- Fixed hinges
- Fridge useable capacity: 179L net
- Freezer useable capacity: 62L net
- Freezing capacity: 10kg/24h
- Total useable capacity: 241L net
- Noise level: 39dBA

Energy efficiency rating

- Energy rating: A+

Energy consumption

- Energy consumption per annum: 300kW.h

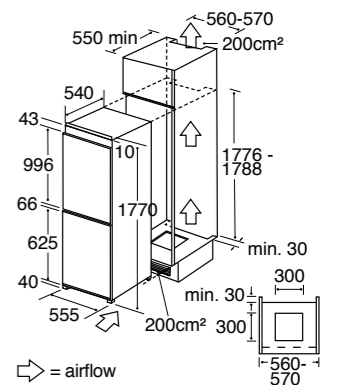

**FF121** Freestanding/under counter larder fridge

## Features

- Interior light
- 3 glass shelves
- 1 salad crisper drawer
- 3 in-door balconies
- 1 egg tray

## Available in

- White

## Technical specification

- Front adjustable feet
- Reversible door
- Height adjustable feet
- Total useable capacity: 106L net
- Noise level: 41dBA

## Energy efficiency rating

- Energy rating: A+

## Energy consumption

- Energy consumption per annum: 115kW.h

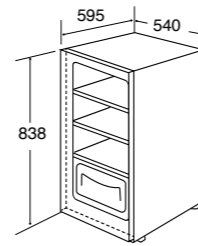
**FF181** Freestanding/under counter freezer

## Features

- 4 star rating
- 3 storage compartments
- 1 ice cube tray

## Available in

- White

## Technical specification

- Front adjustable feet
- Reversible door
- Freezing capacity: 7.5kg/24h
- Total useable capacity: 71L net
- Noise level: 39dBA

## Energy efficiency rating

- Energy rating: A+

## Energy consumption

- Energy consumption per annum: 173kW.h

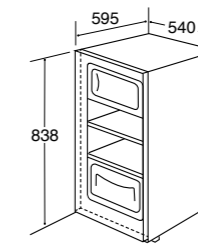
**Top tip**

When introducing new food items to the freezer, select the fast freeze function for a maximum of 24 hours to bring food down to a safe storage temperature quickly.

**FF151** Freestanding/under counter fridge with ice box

## Features

- Interior light
- 2 glass shelves
- 1 salad crisper drawer
- 3 in-door balconies
- 2 egg trays

## Ice box features

- 1 ice cube tray
- 4 star rating

## Available in

- White

## Technical specification

- Front adjustable feet
- Reversible door
- Fridge useable capacity: 105L net
- Ice box useable capacity: 12L net
- Freezing capacity: 2kg/24h
- Total useable capacity: 117L net
- Noise level: 41dBA

## Energy efficiency rating

- Energy rating: A+

## Energy consumption

- Energy consumption per annum: 169 kW.h

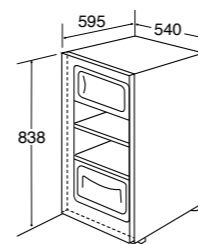
**FF852** Freestanding 50/50 combination fridge freezer

## Fridge features

- Interior light
- 3 glass shelves
- 2 salad crisper drawers
- 6 in-door balconies

## Freezer features

- 2/4 star rating
- Fast freeze
- 4 storage compartments
- 1 ice cube tray

## Available in

- Stainless steel

## Technical specification

- Front adjustable feet/rear castors
- Reversible doors
- Freezing capacity: 8kg/24h
- Fridge useable capacity: 188L net
- Freezer useable capacity: 114L net
- Total useable capacity: 302L net
- Noise level: 44dBA

## Energy efficiency rating

- Energy rating: A+

## Energy consumption

- Energy consumption per annum: 266kW.h

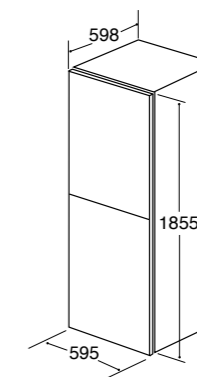

**FF660** Freestanding 60/40 combination frost free fridge freezer

## Features

- Electronic control with LED display
- Door open signal
- Holiday mode

## Fridge features

- Chilled water dispenser
- Multi airflow system
- LED interior lighting
- 4 glass shelves
- 1 salad crisper drawer
- 2 in-door balconies
- 1 lidded dairy compartment
- 2 egg trays

## Freezer features

- 4 star rating
- Fast freeze
- 3 storage compartments
- 1 ice cube tray
- Total no frost

## Available in

- Stainless steel effect



## Technical specification

- Front adjustable feet
- Freezing capacity: 12kg/24h
- Fridge useable capacity: 230L net
- Freezer useable capacity: 92L net
- Total useable capacity: 322L net
- Noise level: 42dBA

## Energy efficiency rating

- Energy rating: A+

## Energy consumption

- Energy consumption per annum: 306kW.h

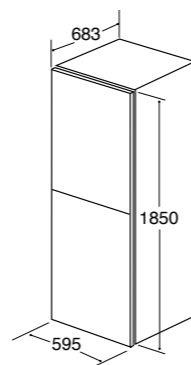
**FF770** Freestanding 70/30 combination frost free fridge freezer

## Features

- Electronic control with LED display
- Door open signal
- Holiday mode
- Easy slide drawer runners

## Fridge features

- Multi airflow system
- LED interior lighting
- 4 glass shelves
- 1 humidity controlled salad crisper drawer
- 4 in-door balconies
- 2 lidded dairy compartments
- 2 egg trays

## Freezer features

- 4 star rating
- Fast freeze
- 3 storage compartments
- Ice cube compartment with twist ice cube maker
- Total no frost

## Available in

- Stainless steel



## Technical specification

- Front adjustable feet
- Freezing capacity: 12kg/24h
- Fridge useable capacity: 285L net
- Freezer useable capacity: 98L net
- Total useable capacity: 383L net
- Noise level: 43dBA

## Energy efficiency rating

- Energy rating: A+

## Energy consumption

- Energy consumption per annum: 349kW.h

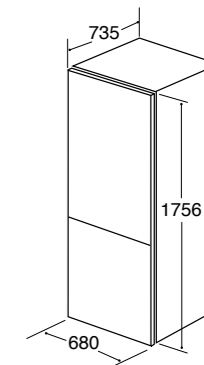

**FF880** Freestanding full height frost free freezer



- Features**
- Electronic control with LED display
  - Door open signal
  - Temperature rise signal
  - 4 star rating
  - Fast freeze
  - 7 storage compartments
  - 2 in-door storage racks
  - Ice cube compartment with twist ice cube maker
  - Frost free
- Available in**
- Stainless steel effect



- Technical specification**
- Front adjustable feet
  - Reversible door
  - Freezing capacity: 16kg/24h
  - Total useable capacity: 260L net
  - Noise level: 45dBA

- Energy consumption**
- Energy consumption per annum: 244kW.h

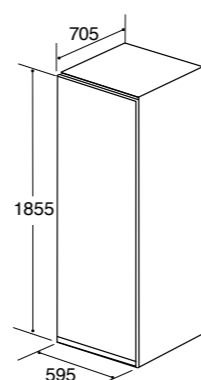

**Did you know?**  
 The FF880 is provided with a joining strip to combine the FF880 freezer and FF820 fridge, creating a spacious and functional food storage solution.



FF820 and FF880 joined configuration

**FF820** Freestanding full height larger fridge



- Features**
- Electronic control with LED display
  - Door open signal
  - Temperature rise signal
  - LED interior lighting
  - 6 adjustable glass shelves
  - 2 salad crispers
  - 4 in-door balconies
  - 1 lidded dairy compartment
  - 2 storage containers
- Available in**
- Stainless steel effect

- Technical specification**
- Front adjustable feet
  - Reversible door
  - Total useable capacity: 350L net
  - Noise level: 43dBA

- Energy consumption**
- Energy consumption per annum: 107kW.h

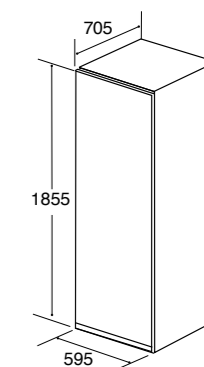

FF820, FWC860 and FF880 joined configuration



FF820 and FF880 joined configuration

Our refrigeration range has been designed with options for every requirement. From integrated or freestanding, to side opening, under counter and in-column, you will find the model that fits your lifestyle. Look out for special features in the range such as ice cube and water dispensers, home bars and smart LCD displays.

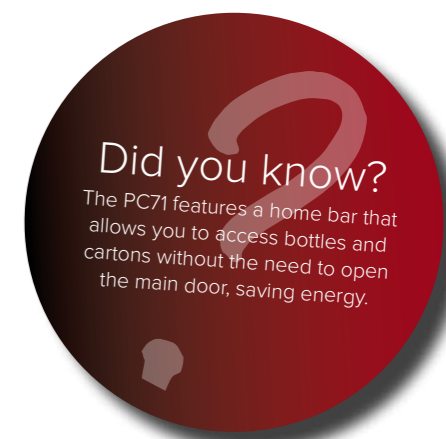

**PC52** American style side-by-side frost free fridge freezer



- Features**
- Electronic control with LED display
  - Temperature rise signal
  - Door open signal
  - Standby function
  - Energy saving
  - Holiday mode
- Fridge features**
- LED interior lighting
  - Super cooling
  - 5 adjustable glass shelves
  - 2 salad crispers
  - 3 in-door balconies
  - 1 egg tray
- Freezer features**
- 4 star rating
  - Fast freeze
  - 2 storage compartments
  - 5 adjustable glass shelves
  - 4 in-door storage racks
  - Ice cube compartment with twist ice cube maker
- Available in**
- Stainless steel effect
  - Black
- Technical specification**
- Front adjustable feet
  - Total no frost
  - Fridge useable capacity: 341L net
  - Freezer useable capacity: 177L net
  - Freezing capacity: 12kg/24h
  - Total useable capacity: 518L net
  - Noise level: 43dBA
- Energy efficiency rating**
- Energy rating: A+
- Energy consumption**
- Energy consumption per annum: 435kW.h

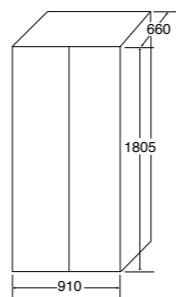

Stainless steel effect    Black



**PC71** American style side-by-side frost free fridge freezer with home bar



- Features**
- Electronic control with LED display
  - Automatic ice dispenser
  - Chilled water dispenser
  - Door open signal
  - Standby function
  - Safety key lock
  - Holiday mode
- Fridge features**
- LED interior lighting
  - Super cooling
  - Home bar
  - 4 adjustable glass shelves
  - 2 salad crispers
  - 4 in-door balconies
- Freezer features**
- 4 star rating
  - Fast freeze
  - 2 storage compartments
  - 3 adjustable glass shelves
  - 2 in-door storage racks
  - Ice cube compartment
- Available in**
- Stainless steel effect
  - Black
- Technical specification**
- Front adjustable feet
  - Total no frost
  - Fridge useable capacity: 375L net
  - Freezer useable capacity: 175L net
  - Freezing capacity: 10kg/24h
  - Total useable capacity: 550L net
  - Noise level: 42dBA
- Energy efficiency rating**
- Energy rating: A+
- Energy consumption**
- Energy consumption per annum: 420kW.h

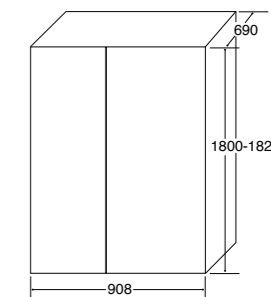

Stainless steel effect    Black



Automatic ice and water dispenser

**PC84** American style two door fridge with frost free two drawer freezer



- Features**
- Electronic control with LCD display
  - Door open signal
- Fridge features**
- LED interior light
  - 3 adjustable glass shelves
  - 2 humidity controlled salad crisper drawers
  - 7 in-door balconies
  - 1 lidded dairy compartment
  - Meat drawer
- Freezer features**
- 4 star rating
  - Fast freeze
- Available in**
- Stainless steel effect

- Technical specification**
- Front adjustable feet
  - Total no frost
  - Fridge useable capacity: 255L net
  - Freezer useable capacity: 95L net
  - Total useable capacity: 350L net
  - Freezing capacity: 10kg/24h
  - Noise level: 45dBA
- Energy efficiency rating**
- Energy rating: A+
- Energy consumption**
- Energy consumption per annum: 305kW.h

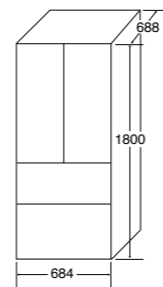

**PC88** American style four door fridge freezer



- Features**
- Electronic control with LED display
  - Door open signal
  - Holiday mode
- Fridge features**
- LED interior lighting
  - 4 adjustable glass shelves
  - 2 salad crispers
  - 6 in-door balconies
  - 2 lidded dairy compartments
- Freezer features**
- 4 star rating
  - 5 storage compartments
  - Ice cube compartment with twist ice cube maker
  - Fast freeze
- Available in**
- Stainless steel effect
  - Black

- Technical specification**
- Front adjustable feet
  - Fridge useable capacity: 307L net
  - Freezer useable capacity: 149L net
  - Freezing capacity: 8kg/24h
  - Total useable capacity: 456L net
  - Noise level: 45dBA
- Energy efficiency rating**
- Energy rating: A+
- Energy consumption**
- Energy consumption per annum: 347kW.h

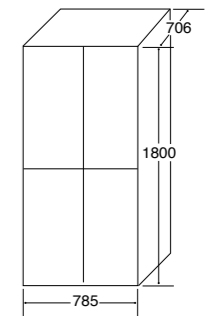

Stainless steel effect      Black





**PC870** American style two door fridge with frost free two drawer freezer



- Features**
- Electronic touch control with LED display
  - Door open signal
  - Holiday mode
  - Temperature rise signal
  - Standby function
  - Energy saving mode
  - Safety key lock
  - Q drink

- Fridge features**
- LED interior lighting
  - Super cooling
  - 3 adjustable glass shelves
  - 2 humidity controlled fruit/veg compartments
  - 2 lidded dairy compartments
  - 6 in-door balconies
  - 1 egg tray
  - Soft close fresh zone drawer

- Freezer features**
- 4 star rating
  - Fast freeze
  - 2 storage compartments
  - 2 ice cube tray

- Available in**
- Stainless steel
  - Black



Stainless steel      Black



LED interior lighting

- Technical specification**
- Height adjustable feet
  - Total no frost
  - Fridge useable capacity: 362L net
  - Freezer useable capacity: 167L net
  - Freezing capacity: 20kg/24h
  - Total useable capacity: 529L net
  - Noise level: 45dBA

- Energy efficiency rating**
- Energy rating: A+

- Energy consumption**
- Energy consumption per annum: 461kW.h

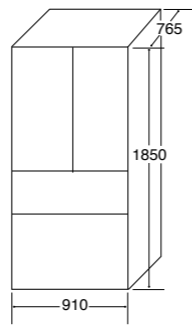

**PC900** American style premium frost free four door fridge freezer



- Features**
- Electronic touch control with LED display
  - Flexi-cool zone
  - Door open signal
  - Holiday mode
  - Temperature rise signal
  - Standby function
  - Energy saving mode
  - Safety key lock
  - Q drink

- Fridge features**
- LED interior lighting
  - Super cooling
  - 3 adjustable glass shelves
  - 2 humidity controlled fruit/veg compartments
  - 2 lidded dairy compartments
  - 6 in-door balconies
  - 1 egg tray
  - Soft close fresh zone drawer

- Freezer features**
- 4 star rating
  - Fast freeze
  - 4 storage compartments
  - 2 shelves
  - 2 ice cube trays

- Available in**
- Stainless steel
  - Black



Stainless steel      Black



LED interior lighting



LED strip lighting

- Technical specification**
- Height adjustable feet
  - Total no frost
  - Fridge useable capacity: 362L net
  - Freezer useable capacity: 164L net
  - Freezing capacity: 13kg/24h
  - Total useable capacity: 526L net
  - Noise level: 46dBA

- Energy efficiency rating**
- Energy rating: A+

- Energy consumption**
- Energy consumption per annum: 459kW.h

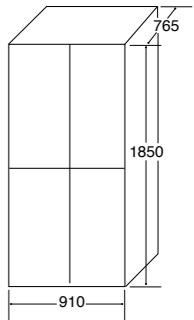

# Wine coolers

Using the latest anti-vibration technology, UV-protection and temperature control, CDA wine coolers keep your collection in optimum condition.



*Variations in temperature, light and movement can all accelerate the ageing process and damage your collection. Installing a wine cooler is a practical and stylish addition to your kitchen. All models come with the latest technology to provide the perfect storage solution.*

## UV-protective toughened smoked glass doors

All CDA wine coolers have UV-protective, toughened, smoked glass doors to prevent sunlight spoiling the wine. This also assists thermal efficiency.



## Luxury wooden shelving

All models feature luxury solid wooden shelves as standard (excludes 15cm slimline models). The FWV901 integrated model also has the addition of a luxury wooden display shelf (shown above).

## Wine cooler glass shelf optional accessory

Our wine cooler glass shelf is perfect for storing smaller items such as bottles and cans - compatible with the FWC303, FWC603, FWC623 and FWC860 models. Please see our accessory section for details.



## Digital temperature control

All CDA wine coolers are designed with electronic temperature control which is adjustable between 5°C and 22°C. The red digital display is easy to use and has a convenient memory function.

## A rated energy efficiency

As we continually move forward and improve our products in response to new technology, our latest range of wine coolers has improved efficiency ratings to save on energy usage in your home.



## Bright LED interior lighting

Bright LED interior lighting illuminates the internal cavity beautifully and makes finding the right bottle quick and easy.

**FWC152** Freestanding/under counter slimline wine cooler

Stainless steel    Black glass

CDA's FWC152 in black glass or stainless steel comes with the same high specification as our larger models but is the perfect size to fill a kitchen gap with useful functionality.

**Features**

- Black plinth
- Red digital display
- Single temperature storage zone
- 6 integrated supports
- Electronic temperature control
- UV-protective toughened smoked glass door
- Double glazed door
- LED interior lighting
- Temperature memory function
- Over temperature alarm
- Height adjustable plinth section
- Safety key lock

**Available in**

- Stainless steel
- Black glass

**Technical specification**

- Reversible door
- Rated electrical power: 60W
- Power supply required: 13A
- Noise level: 41dBA
- Temperature range: 5°C to 22°C
- Total bottle storage: 7 (75cL Bordeaux bottles)
- Compressor driven

**Energy efficiency rating**

- Energy rating: B

**Energy consumption**

- Energy consumption per annum: 186kW.h

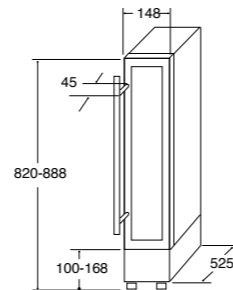
**FWC603** Freestanding/under counter wine cooler

Stainless steel



Black glass

**Features**

- Black plinth
- Red digital display
- Dual temperature storage zones
- 5 wooden slide-out shelves
- Electronic temperature control
- UV-protective toughened smoked glass door
- Double glazed door
- LED interior lighting
- Temperature memory function
- Over temperature alarm
- Height adjustable plinth section
- Integral heater
- Humidifier to maintain 50-80% RH
- Safety key lock

**Optional accessories**

- Glass shelves (pack of 3), AFG61

**Available in**

- Stainless steel
- Black glass

**Technical specification**

- Reversible door
- Rated electrical power: 100W
- Power supply required: 13A
- Noise level: 40dBA
- Temperature range in upper zone: 5°C to 22°C
- Temperature range in lower zone: 5°C to 22°C
- Bottle storage in upper zone: 16 (75cL Bordeaux bottles)
- Bottle storage in lower zone: 30 (75cL Bordeaux bottles)
- Total bottle storage: 46 (75cL Bordeaux bottles)
- Compressor driven

**Energy efficiency rating**

- Energy rating: B

**Energy consumption**

- Energy consumption per annum: 183kW.h

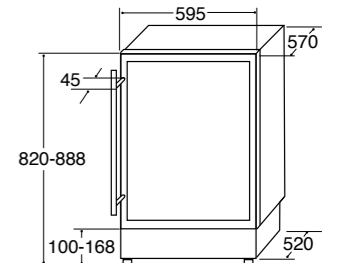
**FWC303** Freestanding/under counter slimline wine cooler

Stainless steel    Black glass

**Features**

- Black plinth
- Red digital display
- Single temperature storage zone
- 5 wooden slide-out shelves
- Electronic temperature control
- UV-protective toughened smoked glass door
- Double glazed door
- LED interior lighting
- Temperature memory function
- Over temperature alarm
- Height adjustable plinth section
- Humidifier to maintain 50-80% RH
- Safety key lock

**Optional accessories**

- Glass shelves (pack of 3), AFG31

**Available in**

- Stainless steel
- Black glass

**Technical specification**

- Reversible door
- Rated electrical power: 85W
- Power supply required: 13A
- Noise level: 39dBA
- Temperature range: 5°C to 22°C
- Total bottle storage: 20 (75cL Bordeaux bottles)
- Compressor driven

**Energy efficiency rating**

- Energy rating: A

**Energy consumption**

- Energy consumption per annum: 139kW.h

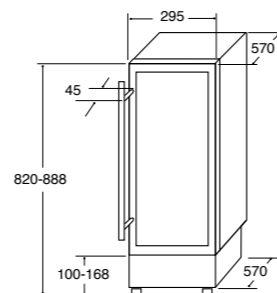
**FWC623** Freestanding/under counter double door wine cooler

Stainless steel



Black glass

Models like the FWC623 offer two storage zones, allowing you to keep both white and red wines perfectly alongside one another.

**Features**

- Black plinth
- Red digital display
- Dual temperature storage zones
- 11 wooden slide-out shelves
- Electronic temperature control
- UV-protective toughened smoked glass doors
- Triple glazed door
- LED interior lighting
- Temperature memory function
- Over temperature alarm
- Height adjustable plinth section
- 2 humidifiers to maintain 50-80% RH
- Safety key lock

**Optional accessories**

- Glass shelves (pack of 3), AFG31

**Available in**

- Stainless steel
- Black

**Technical specification**

- Rated electrical power: 100W
- Power supply required: 13A
- Noise level: 42dBA
- Temperature range in left zone: 5°C to 22°C
- Temperature range in right zone: 5°C to 22°C
- Bottle storage in left zone: 20 (75cL Bordeaux bottles)
- Bottle storage in right zone: 20 (75cL Bordeaux bottles)
- Total bottle storage: 40 (75cL Bordeaux bottles)
- Compressor driven

**Energy efficiency rating**

- Energy rating: B

**Energy consumption**

- Energy consumption per annum: 195kW.h

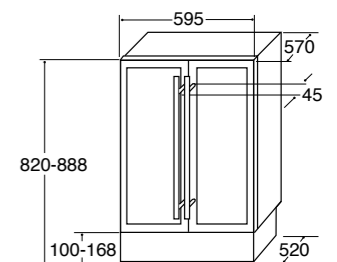

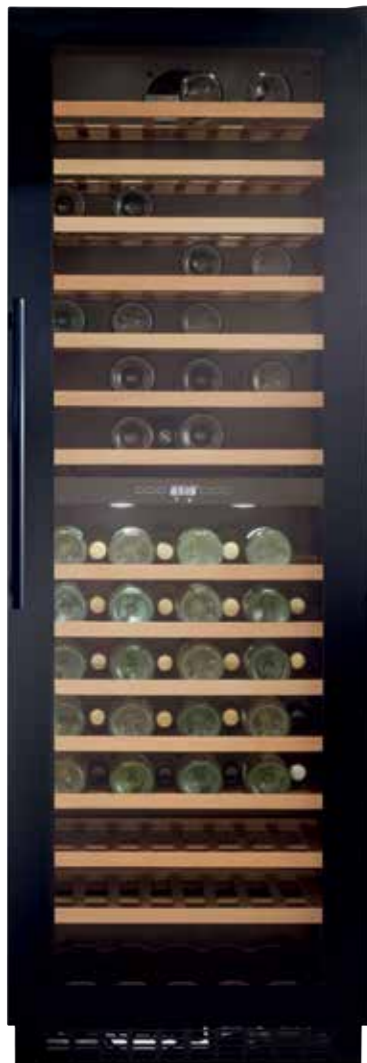
**FWC860** Full height freestanding wine cooler

## Features

- Black plinth
- Red digital display
- Dual temperature storage zones
- 14 wooden slide-out shelves
- Electronic temperature control
- UV-protective toughened smoked glass door
- Triple glazed door
- LED interior lighting
- Energy saving mode
- Temperature memory function
- Over temperature alarm
- Door open alarm
- Humidifier in upper zone to maintain 50-80% RH
- Integral heater
- Safety key lock

## Optional accessories

- Glass shelves (pack of 3), AFG61
- Joining kit, AFJ61

## Available in

- Black



Co-ordinate the FF820, FWC860 and FF880 for the ultimate cooling station. Remember to add an AFJ61 kit containing the joining strips and plinth to seamlessly combine all three appliances.

## Technical specification

- Height adjustable feet
- Reversible door
- Rated electrical power: 160W
- Power supply required: 13A
- Noise level: 45dBA
- Temperature range in upper zone: 5°C to 22°C
- Temperature range in lower zone: 5°C to 22°C
- Bottle storage in upper zone: 64 (75cL Bordeaux bottles)
- Bottle storage in lower zone: 62 (75cL Bordeaux bottles)
- Total bottle storage: 126 (75cL Bordeaux bottles)
- Compressor driven

## Energy efficiency rating

- Energy rating: B

## Energy consumption

- Energy consumption per annum: 225 kWh

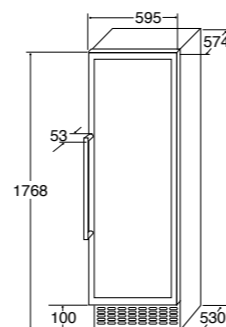
**FWV901** Integrated wine cooler

Black glass

The FWV901 allows you to display your special bottles on a purpose built internal display shelf.

## Features

- Red digital display
- Dual temperature storage zones
- 5 wooden slide-out shelves and 1 wooden display shelf
- Electronic temperature control
- UV-protective toughened smoked glass door
- Triple glazed door
- LED interior lighting
- Temperature memory function
- Over temperature alarm
- Door open alarm
- Energy saving mode
- Display light function
- Humidifier to maintain 50-80% RH
- Safety key lock

## Accessories

- 1 wooden display shelf

## Available in

- Black

## Technical specification

- Reversible door
- Rated electrical power: 100W
- Power supply required: 13A
- Noise level: 41dBA

- Temperature range in upper zone: 5°C to 22°C
- Temperature range in lower zone: 5°C to 22°C
- Bottle storage in upper zone: 28 (75cL Bordeaux bottles)
- Bottle storage in lower zone: 27 (75cL Bordeaux bottles) 25 when using display shelf
- Total bottle storage: 55 or 53 when using display shelf (75cL Bordeaux bottles)
- Compressor driven

## Energy efficiency rating

- Energy rating: B

## Energy consumption

- Energy consumption per annum: 195kWh

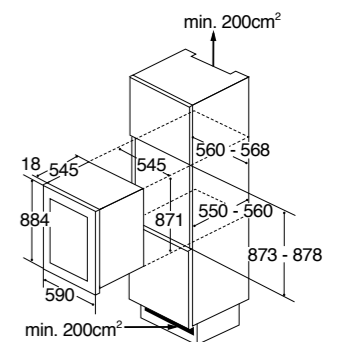
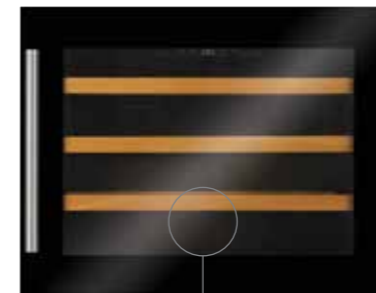
**FWV451** Integrated compact wine cooler

Black glass

The FWV451 will integrate seamlessly into your kitchen design.

## Features

- Red digital display
- Single temperature storage zone
- 3 wooden slide-out shelves
- Electronic temperature control
- UV-protective toughened smoked glass door
- Triple glazed door
- LED interior lighting
- Temperature memory function
- Over temperature alarm
- Door open alarm
- Energy saving mode
- Display light function
- Humidifier to maintain 50-80% RH
- Safety key lock

## Available in

- Black

## Technical specification

- Reversible door
- Rated electrical power: 85W
- Power supply required: 13A
- Noise level: 39dBA
- Temperature range: 5°C to 22°C
- Bottle storage: 24 (75cL Bordeaux bottles)
- Compressor driven

## Energy efficiency rating

- Energy rating: A

## Energy consumption

- Energy consumption per annum: 140kWh

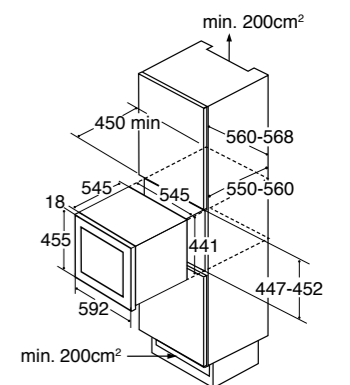



**Integrated compact draught beer dispenser**  
 With an integrated flash chiller, this beer dispenser will have your drink chilled and ready to serve in just 5 minutes.

## FWV600 Integrated compact wine cooler



Black glass

### Features

- Red digital display
- Single temperature storage zone
- 4 wooden slide-out shelves
- Electronic temperature control
- UV-protective toughened smoked glass door
- Triple glazed door
- LED interior lighting
- Temperature memory function
- Over temperature alarm
- Door open alarm
- Energy saving mode
- Display light function
- Humidifier to maintain 50-80% RH
- Safety key lock

### Available in

- Black

### Technical specification

- Reversible door
- Rated electrical power: 100W
- Power supply required: 13A
- Noise level: 39dBA
- Temperature range: 5°C to 22°C
- Bottle storage: 40 (75cL Bordeaux bottles)
- Compressor driven

### Energy efficiency rating

- Energy rating: A

### Energy consumption

- Energy consumption per annum: 140kW.h

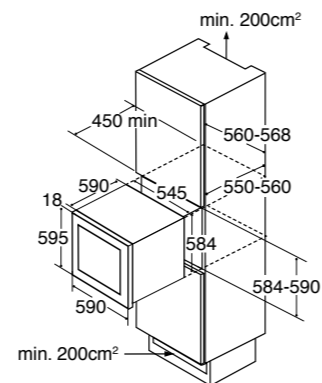

## BVB4 Integrated compact draught beer dispenser



### Features

- Professional fully integrated beer dispenser
- Compatible with 10L, 30L and 50L kegs
- Ready to dispense beer within five minutes of installation without chilling the keg in advance
- Supplied with CO<sub>2</sub> canister
- Temperature controlled by thermostat: 4°C to 8°C
- LED lighting
- Easy cleaning process
- Removable drip tray
- Supplied with S-type connector

### Optional accessories

- Alternative keg connectors, ABC001 (G-type)/ABC005 (A-type)
- CO<sub>2</sub> bottle, ABC002
- Cleaning tablets, ABC003
- Alternative cleaning connectors, ABC004/ABC006



This appliance is supplied with a full professional connecting kit and is designed to fit in a full height unit, which will house the beer keg and connections directly below the built-in dispensing unit.

The line drawing shows the dimensions of the built-in dispensing unit only.

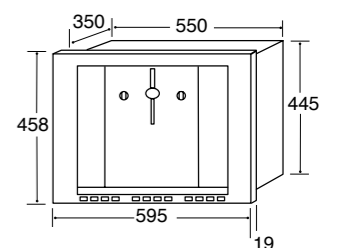

# Dishwashers

CDA dishwashers have been designed with function and performance in mind, with features like hidden controls to keep your programme selection safe from small hands. Combining energy saving features and intelligent technology they deliver perfect results, every time.

*Our intelligent dishwashers sense the level of soiling and select the corresponding temperature and amount of water for the best possible wash performance. Energy and water usage is optimised by using only the energy required for the job and no more.*

## Drying

Special features like Active Drying, on models like the WC600, mean that your dishwasher doesn't rely on passive heat to dry the dishes. Instead, it forces air around the cavity using a fan; drying them quickly and efficiently.



## Energy efficiency

All our dishwashers are A++ rated for energy efficiency.



## Flood protection

All our dishwashers offer leak detection to avoid flood damage in your home. For total peace of mind, the Aquastop system in models like the WC600 dishwasher will automatically cut off the water supply in the event of a leak or flood.



## Water consumption

It is a common misconception that dishwashers use more water than hand washing alone. The average household would complete two lots of hand washing per day, using 21 litres of water each time. With CDA dishwashers using between just 9 and 12 litres of water per load, and holding up to 15 place settings, you can take care of the washing up, your energy usage and water consumption all at the same time, whilst being friendly to the environment.

# Quick guide to dishwashers

CDA dishwashers combine state-of-the-art technology with meticulous build quality to give you reliable performance for years to come.

All our dishwashers feature:

- A++ rating for energy efficiency
- Cold water fill
- Counter-balanced door
- Upper height-adjustable basket to accommodate larger items
- Concealed heating element to protect the bottom basket
- Delay timer to take advantage of off-peak electricity

## Freestanding dishwashers



### WF141

- 13 place settings
  - 6 programmes
  - Delay timer
  - Energy rating: A++
  - Available in white
- More details on p142

### WF610

- 15 place settings
  - 9 programmes
  - Delay timer
  - Top level cutlery basket
  - Energy rating: A++
  - Available in black
- More details on p142

## Slimline integrated dishwashers



### WC432

- 10 place settings
  - 6 programmes
  - Delay timer
  - Energy rating: A++
- More details on p143

### WC480

- 10 place settings
  - 8 programmes
  - Delay timer
  - Top level cutlery basket
  - Half load
  - Energy rating: A++
- More details on p143

## Integrated dishwashers



### WC142

- 13 place settings
  - 5 programmes
  - Delay timer
  - Energy rating: A++
- More details on p144



### WC371

- 13 place settings
  - 9 programmes
  - Delay timer
  - Half load
  - Energy rating: A++
- More details on p144

### WC600

- 15 place settings
  - 9 programmes
  - Delay timer
  - Half load
  - Top level cutlery basket
  - Energy rating: A++
- More details on p145

**WF141** Freestanding dishwasher

## Features

- 13 place settings
- 3/6/9/12 hour delay timer
- 2 spray levels
- LED rinse aid indicator
- LED salt indicator
- LED progress indicator
- Electronic softener adjustment
- Levelling feet with front control
- Height adjustable upper basket
- White baskets

## Programmes

- 6 programmes
  - Prewash (cold)
  - Quick wash 40°C
  - Eco 50°C
  - Super 50 min 65°C
  - Intensive 65°C
  - Extra intensive 70°C

## Available in

- White

## Technical specification

- Rated electrical power: 1.9kW
- Power supply required: 13A
- Noise level: 49dBA

## Energy efficiency rating

- Energy rating: A++
- Wash rating: A
- Drying rating: A

## Energy consumption

- Energy consumption per annum: 285kW.h
- Water consumption per annum: 3360L

- Energy consumption per cycle: 1kW.h

- Water consumption per cycle: 12L

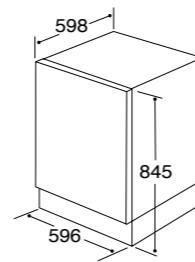
**WC432** Integrated slimline dishwasher

## Features

- 10 place settings
- Half load
- 3/6/9 hour delay timer
- 3 spray levels
- LED rinse aid indicator
- LED salt indicator
- LED progress indicator
- Acoustic signal for end of programme
- Electronic softener adjustment
- Height adjustable upper basket
- Overflow protection
- Levelling feet with front control
- Grey baskets

## Programmes

- 6 programmes
  - Prewash (cold)
  - Quick wash 40°C
  - Eco 50°C
  - Express 65°C
  - Intensive 65°C
  - Intensive+ 70°C

## Technical specification

- Rated electrical power: 1.9kW
- Power supply required: 13A
- Noise level: 49dBA

## Energy efficiency rating

- Energy rating: A++
- Wash rating: A
- Drying rating: A

- Energy consumption per annum: 211kW.h
- Water consumption per annum: 3080L

- Energy consumption per cycle: 0.73kW.h

- Water consumption per cycle: 11L

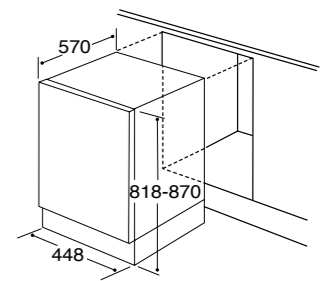
**WF610** Freestanding intelligent dishwasher

## Features

- 15 place settings
- 1-19 hour delay timer
- 3 spray levels
- LED interior light
- LED rinse aid indicator
- LED salt indicator
- Acoustic signal for end of programme
- Electronic softener adjustment
- Active drying system
- Counter balanced door
- Height adjustable upper baskets
- Top level cutlery basket with separate removable sections
- Grey baskets

## Programmes

- 9 programmes
  - Prewash (cold)
  - Quick wash 40°C
  - Eco 50°C
  - Express 60°C
  - Auto normal 50-60°C
  - Auto intensive 60-70°C
  - Auto delicate 30-50°C
  - Intensive 60°C
  - Intensive+ 70°C

## Optional accessories

- Variospace wine glass holder, AWG100

## Technical specification

- Rated electrical power: 1.9kW
- Power supply required: 13A
- Noise level: 45dBA

## Energy efficiency rating

- Energy rating: A++
- Cleaning rating: A
- Drying rating: A

## Energy consumption

- Energy consumption per annum: 267kW.h
- Water consumption per annum: 2520L

- Energy consumption per cycle: 0.94kW.h

- Water consumption per cycle: 9L

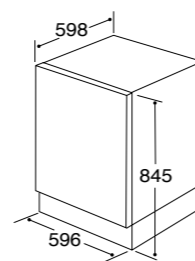

**Did you know?**

Our top of the range WF610 freestanding dishwasher offers the best in technology innovation for perfect wash results, as well as a modern black design to complement your kitchen design.

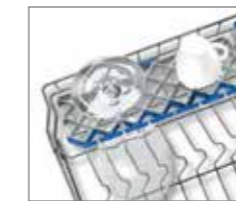
**WC480** Integrated intelligent slimline dishwasher

GlassGuard - wine glass supports

## Features

- 10 place settings
- Half load operates either upper or lower baskets individually or half load of both baskets
- 1-19 hour delay timer
- 3 spray levels
- LED rinse aid indicator
- LED salt indicator
- Acoustic signal for end of programme
- Electronic softener adjustment
- 3-in-1 function
- Levelling feet with front control
- Height adjustable upper basket when loaded
- Overflow protection
- Grey baskets
- Top level cutlery drawer
- GlassGuard - wine glass supports

## Programmes

- 8 programmes
  - Prewash (cold)
  - Quick wash 40°C
  - Eco 50°C
  - 50 minute express wash 65°C
  - Auto normal 50-60°C
  - Auto intensive 60-70°C
  - Auto delicate 30-50°C
  - Intensive+ 70°C

## Optional accessories

- Variospace wine glass holder, AWG100

## Technical specification

- Rated electrical power: 1.9kW
- Power supply required: 13A
- Noise level: 45dBA

## Energy efficiency rating

- Energy rating: A++
- Wash rating: A
- Drying rating: A

- Energy consumption per annum: 211kW.h
- Water consumption per annum: 2520L

- Energy consumption per cycle: 0.73kW.h

- Water consumption per cycle: 9L

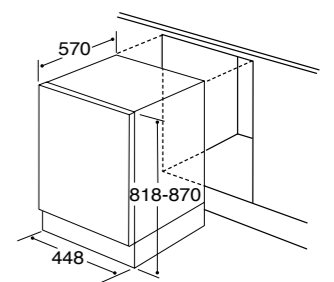



## WC142 Integrated dishwasher



### Features

- 13 place settings
- 3/6/9 hour delay timer
- 2 spray levels
- LED rinse aid indicator
- LED salt indicator
- Acoustic signal for end of programme
- Electronic softener adjustment
- Levelling feet with front control
- Height adjustable upper basket
- White baskets

### Programmes

- 5 programmes
- Prewash (cold)
- Quick wash 40°C
- Eco 50°C
- Super 65°C
- Intensive 70°C

### Technical specification

- Rated electrical power: 1.9kW
- Power supply required: 13A
- Noise level: 49dBA

### Energy efficiency rating

- Energy rating: A++
- Wash rating: A
- Drying rating: A
- Energy consumption per annum: 261kW.h
- Water consumption per annum: 3360L
- Energy consumption per cycle: 0.9kW.h
- Water consumption per cycle: 12L

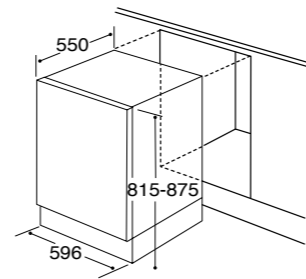

## WC371 Integrated intelligent dishwasher



### Features

- 13 place settings
- Half load operates either upper or lower baskets individually or half load of both baskets
- 1-19 hour delay timer
- 3 spray levels
- LED rinse aid indicator
- LED salt indicator
- Acoustic signal for end of programme
- Electronic softener adjustment
- 3-in-1 function
- Levelling feet with front control
- Height adjustable upper basket when loaded
- Grey baskets
- GlassGuard - wine glass supports

### Programmes

- 9 programmes
- Prewash (cold)
- Quick wash 40°C
- Eco 50°C
- 55 minute express wash 60°C
- Auto normal 50-60°C
- Auto intensive 60-70°C
- Auto delicate 30-50°C
- Intensive 60°C
- Intensive+ 70°C

### Technical specification

- Rated electrical power: 1.9kW
- Power supply required: 13A
- Noise level: 45dBA

### Energy efficiency rating

- Energy rating: A++
- Wash rating: A
- Drying rating: A
- Energy consumption per annum: 261kW.h
- Water consumption per annum: 2520L
- Energy consumption per cycle: 0.9kW.h
- Water consumption per cycle: 9L

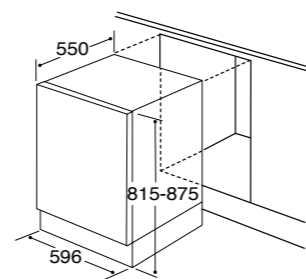

## WC600 Integrated intelligent dishwasher



### Features

- 15 place settings
- LED interior light
- Half load operates either upper or lower baskets individually or half load of both baskets
- 1-19 hour delay timer
- 3 spray levels
- LED rinse aid indicator
- LED salt indicator
- Acoustic signal for end of programme
- Electronic softener adjustment
- Active drying system
- 3-in-1 function
- Levelling feet with front control
- Top level cutlery drawer with separate removable sections
- Height adjustable upper basket when loaded
- Grey baskets with easy grip handles
- Lower basket with folding racks
- Aquastop

### Programmes

- 9 programmes
- Prewash (cold)
- Quick wash 40°C
- Eco 50°C
- 55 minute express wash 60°C
- Auto normal 50-60°C
- Auto intensive 60-70°C
- Auto delicate 30-50°C
- Intensive 60°C
- Intensive+ 70°C

### Optional accessories

- Variospace wine glass holder, AWG100

### Technical specification

- Rated electrical power: 1.9kW
- Power supply required: 13A
- Noise level: 45dBA

### Energy efficiency rating

- Energy rating: A++
- Wash rating: A
- Drying rating: A

### Energy consumption

- Energy consumption per annum: 267kW.h
- Water consumption per annum: 2520L
- Energy consumption per cycle: 0.94kW.h
- Water consumption per cycle: 9L

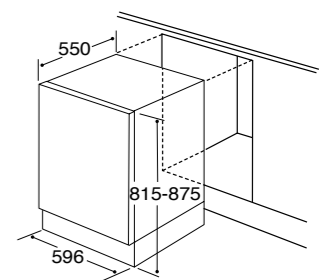

Top level cutlery basket with easy grip handles



Variospace wine glass holder, AWG100 (optional accessory)

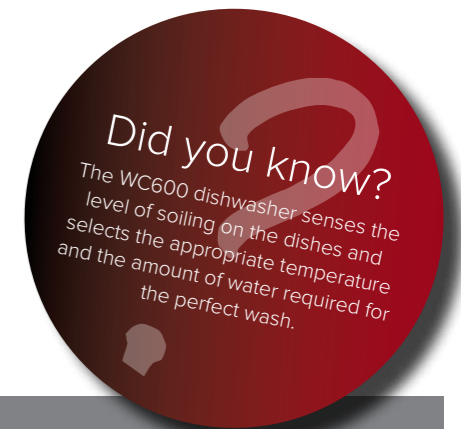



*Look out for our models with an Eco-logic feature. These machines can detect smaller loads and will use less water and power accordingly.*

# Laundry

All of our washing machines are A rated or better for wash performance. Being equipped with the latest programmes and features, they make efficient use of water and energy.

## Choice

CDA's range consists of both integrated and freestanding washing machines, tumble dryers and washer dryers. All models combine high performance with energy efficiency and are perfect for any home.



## Quick wash

All our washers come with a quick wash option making life easier for busy families. We have pioneered super quick wash programmes that can do a wash in just 15 minutes on the CI325, CI371, CI925 and CI971 whilst the CI261 model takes just 12 minutes!



## Advanced technology

The latest technology is used in the development of our high tech laundry products. Intelligent digital sensors that monitor the spin cycle, a choice of up to 15 programmes and special functions such as Quick Wash, Easy Iron and Delicate Wash mean that our machines will deliver great results with every wash load.

## Quick guide to laundry

The CDA laundry range includes integrated and freestanding washing machines, washer dryers and tumble dryers.

All CDA washing machines and washer dryers have the following features:

- Robust stainless steel drum
- Safety door lock
- Cold water fill
- Integrated machines take a full height furniture door which can be hinged on the right or left

### Freestanding washing machine



#### CI261

- 1200 spin speed
  - 9kg wash load
  - Energy rating: A+++
  - Available in white or black
- More details on p150

### Freestanding washer dryer



#### CI860

- 1400 spin speed
  - 8 + 6kg wash load
  - Energy rating: A
- More details on p150

### Freestanding tumble dryer



#### CI522

- 7kg drying load
  - Delicates setting
  - Reversible door
  - Energy rating: C
- More details on p151

### Integrated washing machines



#### CI325

- 1200 spin speed
  - 6kg wash load
  - Energy rating: A++
- More details on p152



#### CI371

- 1400 spin speed
  - 7kg wash load
  - Energy rating: A+
- More details on p153

### Integrated washer dryers



#### CI925

- 1200 spin speed
  - 6 + 3kg wash load
  - Energy rating: B
- More details on p154



#### CI971

- 1400 spin speed
  - 7 + 4kg wash load
  - Energy rating: A
- More details on p154

### Integrated tumble dryer



#### CI921

- 7kg dry load
  - 8 programmes
  - Sensor drying
  - Energy rating: C
- More details on p155

### CI261 High capacity freestanding washing machine



White



Black



This washing machine comes with Eco-logic, a half load detection system that uses less power and water accordingly.

#### Features

- 1200rpm spin speed
- 15 programmes
- 9kg wash load
- Delay timer
- Variable spin speed
- Variable wash temperature
- Eco-logic
- LCD display
- 12 minute quick wash function
- Delicates wash function
- Twin jet
- Anti-flooding safety
- Safety key lock
- Anti-crease function
- Clean pump filter indicator
- Failure detection system

#### Available in

- White
- Black



#### Technical specification

- Rated electrical power: 2.2kW
- Power supply required: 13A
- Noise level: wash 58 / spin 78dBA

#### Energy efficiency rating

- Energy rating: A+++
- Wash rating: A
- Spin rating: B

#### Energy consumption

- Energy consumption per cycle: 1.03kW.h
- Water consumption per cycle: 57L

- Energy consumption per annum: 211kW.h
- Water consumption per annum: 12320L

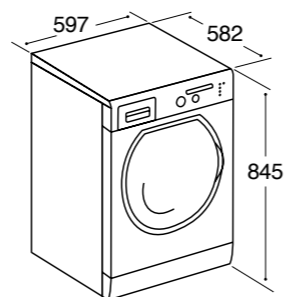

### CI860 High capacity freestanding washer dryer



This washing machine comes with eco-logic, a half load detection system that uses less power and water accordingly.

**Allergysafe**  
The Allergysafe function on the CI860 maintains a 60°C water temperature for an extended period of time to remove 7 allergens and 4 types of bacteria from your laundry, including pollen, pet allergens, dust, mites, fungal and mould spores.

#### Features

- 1400rpm spin speed
- 15 programmes
- 8kg wash load
- 6kg dry load
- Delay timer
- Variable spin speed
- Variable wash temperature
- Eco-logic
- LCD display
- LCD progress indicator
- 15 minute quick wash function
- Extra rinse function
- Easy iron function
- Delicates drying function
- Condensing dryer
- Overflow protection
- Safety key lock
- Balance control
- Allergysafe function

#### Available in

- White



#### Technical specification

- Rated electrical power: 2.2kW
- Power supply required: 13A
- Noise level: wash 58 / spin 77 / dry 64dBA

#### Energy efficiency rating

- Energy rating: A
- Wash rating: A

#### Energy consumption

- Energy consumption per cycle: 5.44kW.h
- Water consumption per cycle: 112L

- Energy consumption per annum: 1197kW.h
- Water consumption per annum: 24640L

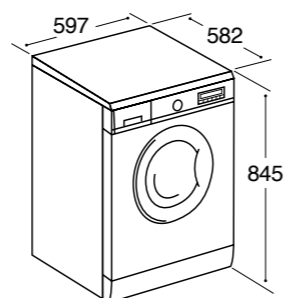

### CI522 Freestanding tumble dryer



#### Features

- 7kg dry load
- Analogue progress indicator
- Vented dryer
- Variable drying duration
- Delicates setting
- Reversible door

#### Available in

- White



#### Technical specification

- Rated electrical power: 2.7kW
- Power supply required: 13A
- Noise level: 62dBA

#### Energy efficiency rating

- Energy rating: C

#### Energy consumption

- Energy consumption per cycle: 4.48kW.h

- Energy consumption per annum: 519kW.h

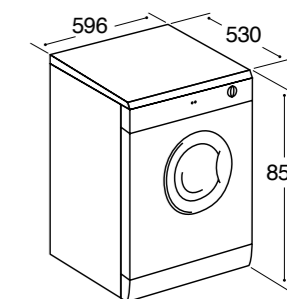

### CI325 Integrated washing machine



#### Features

- 1200rpm spin speed
- 11 programmes
- 6kg wash load
- Delay timer
- Variable wash temperature
- Variable spin speed
- 15 minute quick wash function
- Delicates wash function
- Cold wash
- Wool wash
- LED display
- Safety key lock
- Anti-crease function
- Extra rinse function
- Intensive wash function
- Acoustic signal for end of programme

#### Available in

- White



#### Technical specification

- Rated electrical power: 2kW
- Power supply required: 13A
- Noise level: wash 57 / spin 75dBA

#### Energy efficiency rating

- Energy rating: A++
- Wash rating: A
- Spin rating: B

#### Energy consumption

- Energy consumption per cycle: 0.80kW.h
- Water consumption per cycle: 50L
- Energy consumption per annum: 166kW.h
- Water consumption per annum: 11003L

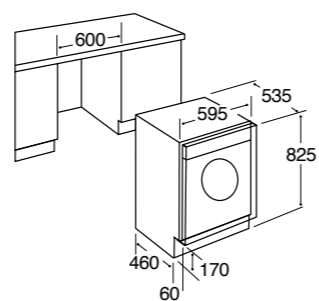

### CI371 Integrated washing machine



#### Features

- 1400rpm spin speed
- 15 programmes
- 7kg wash load
- Delay timer
- Variable spin speed
- Intelligent spin control
- Flexible quick wash function
- Delicates wash function
- Cold wash
- Wool wash
- LED display
- Safety key lock
- Anti-crease function
- Extra rinse function
- Easy iron function
- Intensive wash function
- Acoustic signal for end of programme
- Balance control
- Total aquastop

#### Available in

- White



#### Technical specification

- Rated electrical power: 2.2kW
- Power supply required: 13A
- Noise level: wash 56 / spin 72dBA

#### Energy efficiency rating

- Energy rating: A+
- Wash rating: A
- Spin rating: B

#### Energy consumption

- Energy consumption per cycle: 1.08kW.h
- Water consumption per cycle: 47L
- Energy consumption per annum: 218kW.h
- Water consumption per annum: 10340L

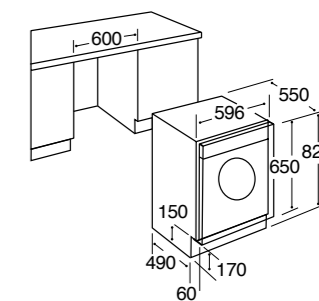

### CI925 Integrated washer dryer



#### Features

- 1200rpm spin speed
- 11 programmes
- 6kg wash load
- 3kg dry load
- Delay timer
- Variable wash temperature
- Variable spin speed
- 15 minute quick wash function
- Intensive wash function
- Extra rinse function
- Drum clean programme
- Condensing dryer
- Acoustic signal for end of programme
- LED display
- Safety key lock

#### Available in

- White



#### Technical specification

- Rated electrical power: 2kW
- Power supply required: 13A
- Noise level: wash 59 / spin 76 / dry 58dBA

#### Energy efficiency rating

- Energy rating: B
- Wash rating: A

#### Energy consumption

- Energy consumption per cycle: 4.85kW.h
- Water consumption per cycle: 108L

- Energy consumption per annum: 1065kW.h
- Water consumption per annum: 23760L

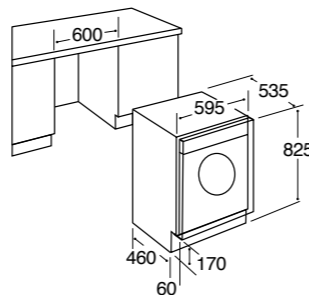

### CI921 Integrated tumble dryer



#### Features

- 7kg dry load
- Sensor dryer
- Vented dryer
- 2 heat settings
- Reversible door
- 8 programmes
- Safety key lock
- Timed drying programme
- Airing programme

#### Available in

- White



#### Technical specification

- Rated electrical power: 2kW
- Power supply required: 13A
- Noise level: 62dBA

#### Energy efficiency rating

- Energy rating: C

#### Energy consumption

- Energy consumption per cycle: 4.39kW.h

- Energy consumption per annum: 519kW.h

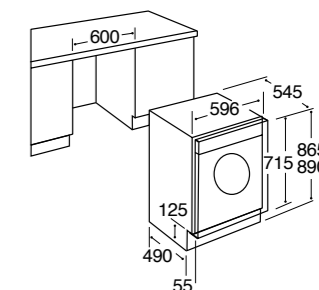

### CI971 Integrated washer dryer



#### Features

- 1400rpm spin speed
- 15 programmes
- 7kg wash load
- 4kg dry load
- Delay timer
- Variable spin speed
- Intelligent spin control
- Flexible quick wash function
- Delicates setting
- LED display
- Anti-crease function
- Extra rinse function
- Easy iron function
- Intensive wash function
- Condensing dryer
- Acoustic signal for end of programme
- Variable drying duration
- Safety key lock
- Balance control
- Anti-flooding safety
- Total aquastop

#### Available in

- White



#### Technical specification

- Rated electrical power: 2.2kW
- Power supply required: 13A
- Noise level: wash 56 / spin 72 / dry 58dBA

#### Energy efficiency rating

- Energy rating: A
- Wash rating: A

#### Energy consumption

- Energy consumption per cycle: 4.76kW.h
- Water consumption per cycle: 99L

- Energy consumption per annum: 952kW.h
- Water consumption per annum: 19800L

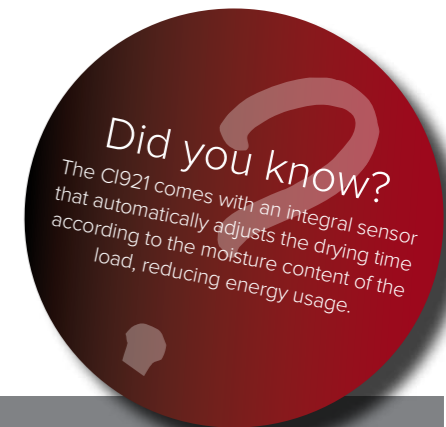
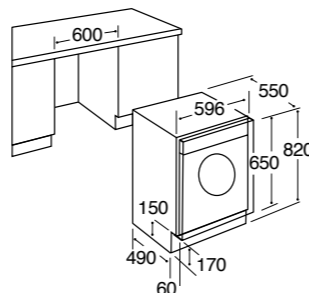

# Sinks

The CDA sink range includes stainless steel, composite, ceramic and glass in either contemporary or traditional designs to suit any kitchen.

*Our comprehensive sink range offers maximum impact combined with cutting edge technology - the K980 even has Ariapura where titanium dioxide nanoparticles actively purify the air around your sink.*

## Ceramic

Made from incredibly robust, fine fireclay with a hard, glossy finish, these sinks are easy to clean and extremely durable. Our choice of styles includes contemporary single or one and a half bowl sinks, traditional Belfast styles and even ceramic undermount sinks.



## Glass

The stunning KVL02 is an innovative glass sink which co-ordinates perfectly with our black glass appliances and hobs. It is constructed from robust scratch, stain and heat resistant glass and finished with an elegant bevelled edge.

## Stainless steel

All CDA sinks are constructed from premium 304 grade stainless steel for superb quality. Stainless steel is resistant to heat and household chemicals, and is easy to clean. It has a smooth, non-porous surface making it very practical and hygienic.



## Flush-fit

Create a continuous, smooth worktop line throughout your kitchen with a flush fit sink. Unlike an overmount sink this range sits flush with the worktop resulting in an easy to clean, contemporary look.

## Composite

Made from a mixture of quartz or granite blended with acrylic resin for durability, our composite sinks are hard wearing and combine the natural look of stone with the benefits of a modern material.

# Quick guide to sinks

The CDA range of sinks includes stainless steel, ceramic, composite and even glass models. Undermount sinks are also available in either stainless steel or ceramic materials.

Most CDA sinks are supplied with pipework included and have large 3.5" strainer wastes.

## Stainless steel sinks

All stainless steel sinks from CDA are manufactured from premium quality 304 grade steel. This gives the sink a high resistance to corrosion and rust, with the ability to withstand all common household detergents. They are also extremely hygienic and easy to clean.

## Ceramic sinks

CDA ceramic sinks have a hard, non-porous surface with a tough, gloss finish. They are extremely durable and are resistant to both chemicals and heat. We offer a variety of styles from contemporary to traditional, including the classic "Belfast" model, available in both a single and double bowl option.

Please note: Ceramic sinks are traditionally made and each one will have individual characteristics. This may cause dimensions to vary from those shown in the brochure by between 2 and 5%.

## Composite sinks

Our composite sinks are made of natural granite or quartz combined with acrylic resin to give a durable and hard wearing sink.

Like the natural stone, particles of granite combined with resin give these sinks an authentic flecked finish that is incredibly hard wearing.

## Accessories

Look out for the useful optional accessories which are available to help make your life easy. Our accessories are designed to work perfectly with the compatible sinks.

## Undermount sinks

Also available but not shown in detail here:



### undermount sink range

See p176-185

## Stainless steel



### KR20

- Single round drainer
  - Fits in 450mm base unit
- More details on p160



### KR21

- Single round bowl sink
  - Fits in 450mm base unit
- More details on p160



### KA30

- Compact single bowl sink
  - Reversible
  - Fits in 500mm base unit
- More details on p162



### KA32

- One and a half bowl sink
  - Reversible
  - Fits in 600mm base unit
- More details on p162



### KA71

- Large single bowl sink
  - Reversible
  - Fits in 600mm base unit
- More details on p164



### KA72

- One and a half bowl sink
  - Reversible
  - Fits in 600mm base unit
- More details on p164



### KVL01/KVL01L

- Glass single bowl sink
  - Scratch, stain and heat resistant
  - Fits in 600mm base unit
- More details on p167



### KVL02/KVL02L

- Glass one and a half bowl sink
  - Scratch, stain and heat resistant
  - Fits in 800mm base unit
- More details on p167



### KG73

- Composite single bowl sink
  - Granite/quartz construction
  - Fits in 600mm base unit
  - Reversible
  - Available in anthracite or graphite
- More details on p170



### KG74

- Composite one and a half bowl sink
  - Granite/quartz construction
  - Fits in 600mm base unit
  - Reversible
  - Available in anthracite or graphite
- More details on p170



### KC11

- Ceramic Belfast single bowl sink
  - Fireclay construction
- More details on p173



### KC12

- Ceramic Belfast double bowl sink
  - Fireclay construction
- More details on p173



### CCP3

- Double bowl corner sink
  - Polished finish
- More details on p160



### KA20

- Compact single bowl sink
  - Reversible
  - Fits in 450mm base unit
- More details on p161



### KA21

- Single bowl sink
  - Reversible
  - Fits in 450mm base unit
- More details on p161



### KA22

- One and a half bowl sink
  - Reversible
  - Fits in 600mm base unit
- More details on p161



### KA55

- Single bowl sink with mini drainer
  - Reversible
  - Fits in 450mm base unit
- More details on p163



### KA50

- Compact single bowl sink
  - Reversible
  - Fits in 450mm base unit
- More details on p163



### KA52

- One and a half bowl sink
  - Reversible
  - Fits in 600mm base unit
- More details on p163



### KA80

- Single bowl sink
  - Reversible
  - Fits in 500mm base unit
- More details on p165



### KA82

- One and a half bowl sink
  - Reversible
  - Fits in 600mm base unit
- More details on p165



### KVF21R/KVF21L

- Single bowl flush-fit sink
  - Slim top profile
  - Fits in 600mm base unit
- More details on p166



### KVF22R/KVF22L

- One and a half bowl flush-fit sink
  - Slim top profile
  - Fits in 600mm base unit
- More details on p166

## Composite



### AS1

- Composite single bowl sink
  - Composite granite construction
  - Fits in 450mm base unit
  - Reversible
  - Available in white or cream
- More details on p168



### AS2

- Composite one and a half bowl sink
  - Composite granite construction
  - Fits in 600mm base unit
  - Reversible
  - Available in white or cream
- More details on p168



### KG43

- Composite single bowl sink
  - Granite/quartz construction
  - Reversible
  - Fits in 600mm base unit
- More details on p169



### KG44

- Composite one and a half bowl sink
  - Granite/quartz construction
  - Reversible
  - Fits in 600mm base unit
- More details on p169



### KG81

- Composite single bowl sink with stainless steel drainer bars
  - Granite/quartz construction
  - Fits in 600mm base unit
  - Reversible
  - Available in anthracite or graphite
- More details on p171



### KG82

- Composite one and a half bowl sink with stainless steel drainer bars
  - Granite/quartz construction
  - Fits in 600mm base unit
  - Reversible
  - Available in anthracite or graphite
- More details on p171



### KG80

- Composite double bowl sink with metallic finish
  - Ariapura technology
  - Fits in 900mm base unit
- More details on p172



### KC23

- Ceramic single bowl sink
  - Heavy duty
  - Reversible
  - Fits in 600mm base unit
- More details on p174



### KC24

- Ceramic one and a half bowl sink
  - Heavy duty
  - Reversible
  - Fits in 600mm base unit
- More details on p174



### KC73

- Ceramic classic design single bowl sink
  - Heavy duty
  - Reversible
  - Fits in 600mm base unit
- More details on p175



### KC74

- Ceramic classic design one and a half bowl sink
  - Heavy duty
  - Reversible
  - Fits in 600mm base unit
- More details on p175



**KR20** Stainless steel round drainer

## Features

- Polished finish

## Accessories

- Waste kit
- Plumbing pack

## Optional accessories

- Waste disposer, AKD01/AKD02
- Space saver plumbing pack, PP1

## Available in

- Stainless steel

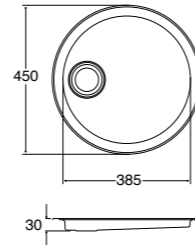
**KR21** Stainless steel round single bowl sink

## Features

- Polished finish
- Fits in 450mm base unit

## Accessories

- Waste kit
- Plumbing pack

## Optional accessories

- Stainless steel basket, AKB05
- Wooden chopping board, AKW05
- Waste disposer, AKD01/AKD02
- Space saver plumbing pack, PP1

## Available in

- Stainless steel

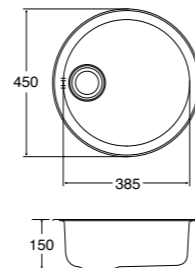
**CCP3** Stainless steel corner double bowl sink

## Features

- Polished finish
- 1mm heavy gauge stainless steel construction

## Optional accessories

- Wooden chopping board, TRE
- Waste disposer, AKD01/AKD02
- Space saver plumbing pack, PP2

## Available in

- Stainless steel

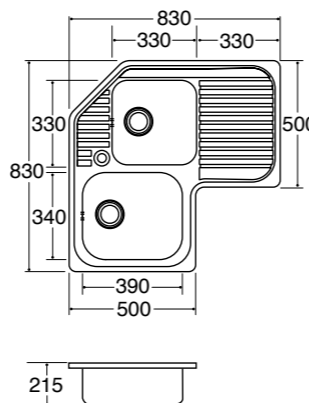
**KA20** Stainless steel compact single bowl sink

## Features

- Polished finish
- Reversible
- Fits in 450mm base unit

## Accessories

- Waste kit
- Plumbing pack

## Optional accessories

- Wooden chopping board, AKW20
- Waste disposer, AKD01/AKD02
- Space saver plumbing pack, PP1

## Available in

- Stainless steel

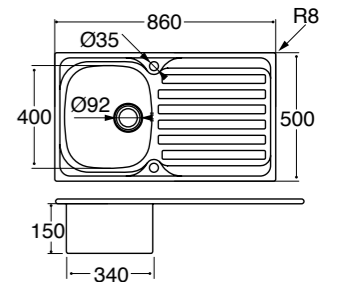

## Optional accessory

The AKW20 wooden chopping board is the perfect accessory for the KA20, KA21 and KA22 sinks.

**KA21** Stainless steel single bowl sink

## Features

- Polished finish
- Reversible
- Fits in 450mm base unit

## Accessories

- Waste kit
- Plumbing pack

## Optional accessories

- Wooden chopping board, AKW20
- Waste disposer, AKD01/AKD02
- Space saver plumbing pack, PP1

## Available in

- Stainless steel

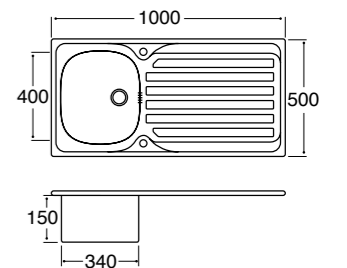

## Optional accessory

The AKW20 wooden chopping board is the perfect accessory for the KA20, KA21 and KA22 sinks.

**KA22** Stainless steel one and a half bowl sink

## Features

- Polished finish
- Reversible
- Fits in 600mm base unit

## Accessories

- Waste kit
- Plumbing pack

## Optional accessories

- Wooden chopping board, AKW20
- Waste disposer, AKD01/AKD02
- Space saver plumbing pack, PP2

## Available in

- Stainless steel

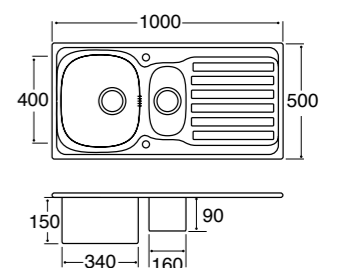

## Optional accessory

The AKW20 wooden chopping board is the perfect accessory for the KA20, KA21 and KA22 sinks.



**KA30** Stainless steel compact single bowl sink

## Features

- Polished finish
- Reversible
- Fits in 500mm base unit

## Accessories

- Waste kit
- Plumbing pack

## Optional accessories

- Sliding wooden chopping board, AKW38
- Waste disposer, AKD01/AKD02
- Space saver plumbing pack, PP1

## Available in

- Stainless steel

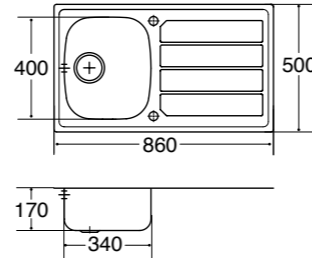

## Optional accessory

The AKW38 sliding wooden chopping board is the perfect accessory for the KA30.

**KA32** Stainless steel one and a half bowl sink

## Features

- Polished finish
- Reversible
- Fits in 600mm base unit

## Accessories

- Waste kit
- Plumbing pack

## Optional accessories

- Sliding wooden chopping board, AKW38
- Stainless steel basket, AKB38
- Waste disposer, AKD01/AKD02
- Space saver plumbing pack, PP2

## Available in

- Stainless steel

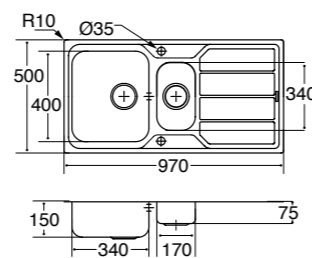

## Optional accessories

The AKB38 stainless steel basket and AKW38 sliding wooden chopping board are the perfect accessories for the KA32.

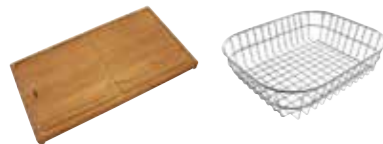
**KA55** Stainless steel single bowl sink with mini drainer

## Features

- Polished finish
- Reversible
- Fits in 450mm base unit

## Accessories

- Waste kit
- Plumbing pack

## Optional accessories

- Wooden chopping board, AKW57
- Stainless steel basket, AKB57
- Waste disposer, AKD01/AKD02
- Space saver plumbing pack, PP1

## Available in

- Stainless steel

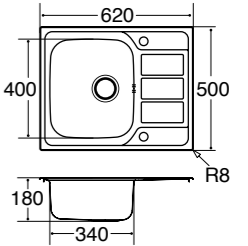

## Optional accessories

The AKW57 wooden chopping board and AKB57 stainless steel basket are the perfect accessories for the KA55, KA50 and KA52 sinks.

**KA50** Stainless steel compact single bowl sink

## Features

- Polished finish
- Reversible
- Fits in 500mm base unit

## Accessories

- Waste kit
- Plumbing pack

## Optional accessories

- Wooden chopping board, AKW57
- Stainless steel basket, AKB57
- Waste disposer, AKD01/AKD02
- Space saver plumbing pack, PP1

## Available in

- Stainless steel

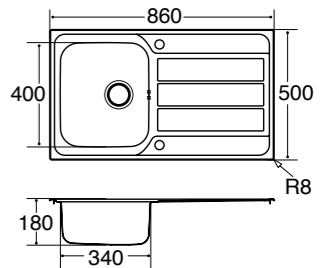

## Optional accessories

The AKW57 wooden chopping board and AKB57 stainless steel basket are the perfect accessories for the KA55, KA50 and KA52 sinks.

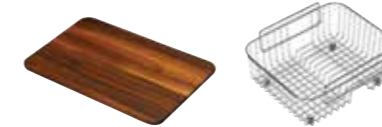
**KA52** Stainless steel one and a half bowl sink

## Features

- Polished finish
- Reversible
- Fits in 600mm base unit

## Accessories

- Waste kit
- Plumbing pack

## Optional accessories

- Wooden chopping board, AKW57
- Stainless steel basket, AKB57
- Waste disposer, AKD01/AKD02
- Space saver plumbing pack, PP2

## Available in

- Stainless steel

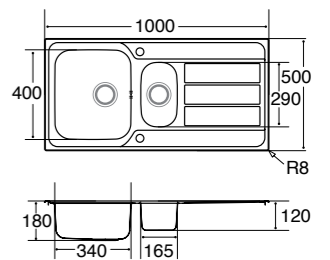

## Optional accessories

The AKW57 wooden chopping board and AKB57 stainless steel basket are the perfect accessories for the KA55, KA50 and KA52 sinks.

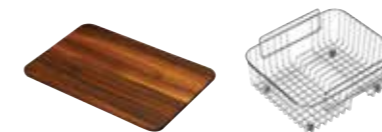

**KA71** Stainless steel large single bowl sink

## Features

- Polished finish
- Reversible
- Extra large bowl
- Fits in 600mm base unit

## Accessories

- Waste kit
- Plumbing pack

## Optional accessories

- Wooden chopping board, AKW03
- Waste disposer, AKD01/AKD02
- Space saver plumbing pack, PP1

## Available in

- Stainless steel

## Optional accessory

The AKW03 wooden chopping board is the perfect accessory for the KA71 sink.

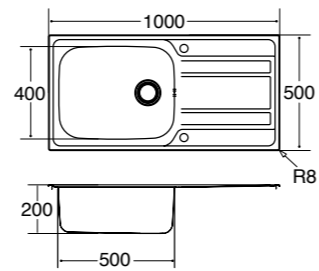
**KA80** Stainless steel single bowl sink

## Features

- Polished, satinised finish for an extra smooth, easy to clean surface
- Reversible
- Fits in 500mm base unit
- Larger bowl
- Recessed water-safe perimeter profile

## Accessories

- Waste kit
- Plumbing pack

## Optional accessories

- Sliding wooden chopping board, AKW38
- Stainless steel basket, AKB38
- Waste disposer, AKD01/AKD02
- Space saver plumbing pack, PP1

## Available in

- Stainless steel

## Optional accessories

The AKB38 stainless steel basket and AKW38 sliding wooden chopping board are the perfect accessories for the KA80 and KA82 sinks.

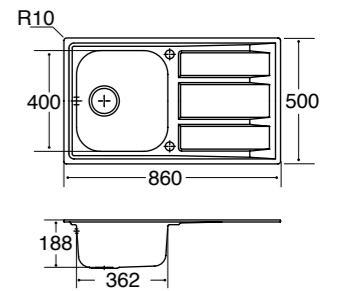
**KA72** Stainless steel one and a half bowl sink

## Features

- Polished finish
- Reversible
- Fits in 600mm base unit

## Accessories

- Waste kit
- Plumbing pack

## Optional accessories

- Wooden chopping board, AKW57
- Stainless steel basket, AKB57
- Waste disposer, AKD01/AKD02
- Space saver plumbing pack, PP2

## Available in

- Stainless steel

## Optional accessories

The AKW57 wooden chopping board and AKB57 stainless steel basket are the perfect accessories for the KA72 sink.

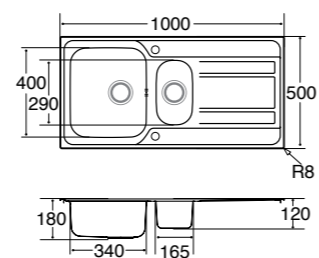
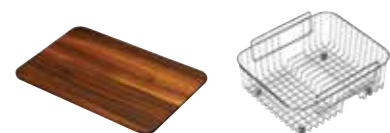
**KA82** Stainless steel one and a half bowl sink

## Features

- Polished, satinised finish for an extra smooth, easy to clean surface
- Reversible
- Fits in 600mm base unit
- Recessed water-safe perimeter profile

## Accessories

- Waste kit
- Plumbing pack

## Optional accessories

- Sliding wooden chopping board, AKW38
- Stainless steel basket, AKB38
- Waste disposer, AKD01/AKD02
- Space saver plumbing pack, PP2

## Available in

- Stainless steel

## Optional accessories

The AKB38 stainless steel basket and AKW38 sliding wooden chopping board are the perfect accessories for the KA80 and KA82 sinks.

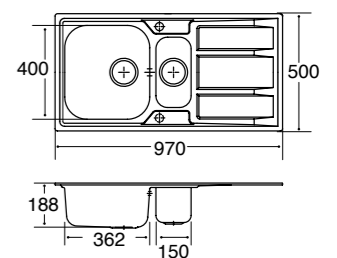
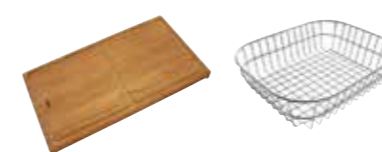

**KVF21** Single bowl flush-fit sink

KVF21R



KVF21L

**Features**

- Extra large bowl
- Flush-fit, slim top profile
- Fits in 600mm base unit
- 1mm heavy gauge stainless steel construction
- Noise deadening pads

**Accessories**

- Concealed overflow
- Waste kit
- Plumbing pack

**Optional accessories**

- Stainless steel main bowl colander, AKC12
- Waste disposer, AKD01/AKD02
- Space saver plumbing pack, PP1

**Available in**

- Stainless steel - right hand drainer, KVF21R
- Stainless steel - left hand drainer, KVF21L

**Optional accessory**

The AKC12 stainless steel main bowl colander is the perfect accessory for KVF21 and KVF22 sinks. This colander is designed to fit the main bowl only.

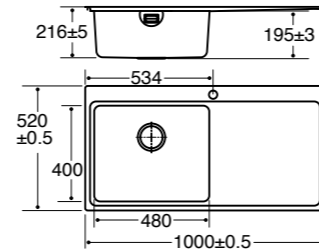
**KVL01** Glass single bowl sink

KVL01



KVL01L

**Features**

- Extra large bowl
- Toughened glass
- Scratch, stain and heat resistant
- Fits in 600mm base unit
- Noise deadening pads

**Accessories**

- Concealed overflow
- Waste kit
- Plumbing pack

**Optional accessories**

- Stainless steel main bowl colander, AKC12
- Waste disposer, AKD01/AKD02
- Space saver plumbing pack, PP1

**Available in**

- Black - right hand drainer, KVL01
- Black - left hand drainer, KVL01L

**Optional accessory**

The AKC12 stainless steel main bowl colander is the perfect accessory for KVL01 and KVL02 sinks.

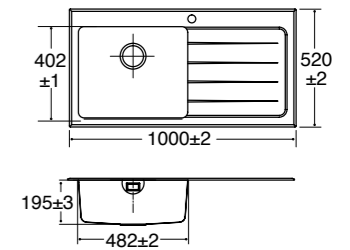

Strong, toughened glass for a robust scratch and heat resistant draining surface.

**KVF22** One and a half bowl flush-fit sink

KVF22R



KVF22L

**Features**

- Flush-fit, slim top profile
- Fits in 600mm base unit
- 1mm heavy gauge stainless steel construction
- Noise deadening pads

**Accessories**

- Concealed overflow
- Waste kit
- Plumbing pack

**Optional accessories**

- Stainless steel main bowl colander, AKC12
- Waste disposer, AKD01/AKD02
- Space saver plumbing pack, PP2

**Available in**

- Stainless steel - right hand drainer, KVF22R
- Stainless steel - left hand drainer, KVF22L

**Optional accessory**

The AKC12 stainless steel main bowl colander is the perfect accessory for KVF21 and KVF22 sinks. This colander is designed to fit the main bowl only.

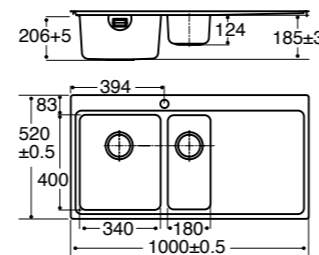
**KVL02** Glass one and a half bowl sink

KVL02



KVL02L

**Features**

- Toughened glass
- Scratch, stain and heat resistant
- Fits in 800mm base unit
- Noise deadening pads

**Accessories**

- Concealed overflow
- Waste kit
- Plumbing pack

**Optional accessories**

- Stainless steel main bowl colander, AKC12
- Waste disposer, AKD01/AKD02
- Space saver plumbing pack, PP2

**Available in**

- Black - right hand drainer, KVL02
- Black - left hand drainer, KVL02L

**Optional accessory**

The AKC12 stainless steel main bowl colander is the perfect accessory for KVL01 and KVL02 sinks.

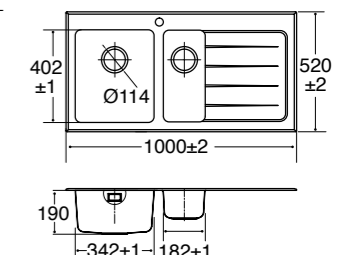

**AS1** Composite single bowl sink

## Features

- Composite granite construction
- Scratch resistant
- Reversible
- Fits in 450mm base unit



## Accessories

- Waste kit
- Plumbing pack

## Optional accessories

- Accessory pack: stainless steel main bowl basket, wooden chopping board, PA1
- Waste disposer, AKD01/AKD02
- Space saver plumbing pack, PP1

## Available in

-  White (as shown)
-  Cream

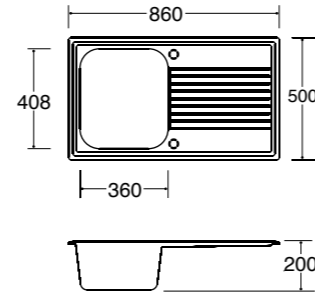

## Optional accessories

The PA1 sink accessory pack contains a stainless steel main bowl basket and wooden chopping board.

**AS2** Composite one and a half bowl sink

## Features

- Composite granite construction
- Scratch resistant
- Reversible
- Fits in 600mm base unit



## Accessories

- Waste kit
- Plumbing pack

## Optional accessories

- Accessory pack: stainless steel main bowl basket, small stainless steel basket, wooden chopping board, PA2
- Waste disposer, AKD01/AKD02
- Space saver plumbing pack, PP2

## Available in

-  White
-  Cream (as shown)

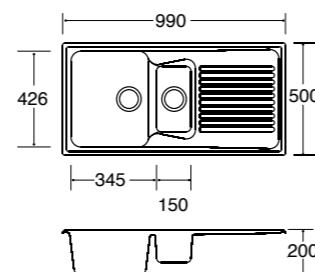

## Optional accessories

The PA2 sink accessory pack contains a stainless steel main bowl basket, stainless steel half bowl basket and wooden chopping board.

**KG43** Composite single bowl sink

## Features:

- Granite/quartz construction
- Scratch resistant
- Tough and hygienic
- Super smooth metallic finish
- Reversible
- Fits in 600mm base unit
- New and exclusive strainer design

## Accessories

- Concealed overflow
- Waste kit
- Plumbing pack

## Available in:

- Anthracite

## Optional accessories:

- Black glass chopping board, AKG47
- Stainless steel main bowl colander, AKC48
- Waste disposer, AKD01/AKD02
- Space saver plumbing pack, PP1

## Optional accessories

The AKG47 glass chopping board and AKC48 stainless steel main bowl colander make preparing food quick and easy.

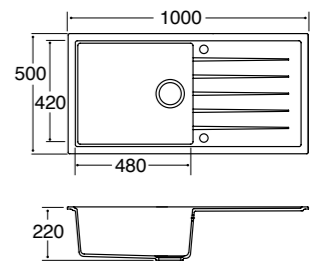
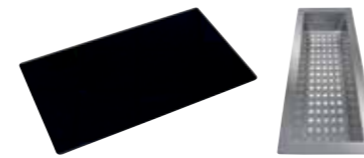
**KG44** Composite one and a half bowl sink

## Features:

- Granite/quartz construction
- Scratch resistant
- Tough and hygienic
- Super smooth metallic finish
- Reversible
- Fits in 600mm base unit
- New and exclusive strainer design

## Accessories

- Concealed overflow
- Waste kit
- Plumbing pack

## Available in:

- Anthracite

## Optional accessories:

- Black glass chopping board, AKG47
- Stainless steel main bowl colander, AKC48
- Waste disposer, AKD01/AKD02
- Space saver plumbing pack, PP2

## Optional accessories

The AKG47 glass chopping board and AKC48 stainless steel main bowl colander make preparing food quick and easy.

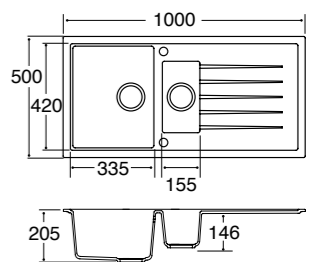
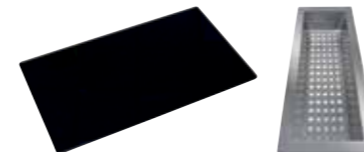

**KG73** Composite single bowl sink

Anthracite



Graphite

**Features:**

- Granite/quartz construction
- Scratch resistant
- Tough and hygienic
- Super smooth metallic finish
- Reversible
- Fits in 600mm base unit
- New and exclusive strainer design

**Accessories**

- Concealed overflow
- Waste kit
- Plumbing pack

**Available in:**

- Anthracite
- Graphite

**Optional accessories:**

- Black glass chopping board, AKG47
- Stainless steel main bowl colander, AKC48
- Waste disposer, AKD01/AKD02
- Space saver plumbing pack, PP1

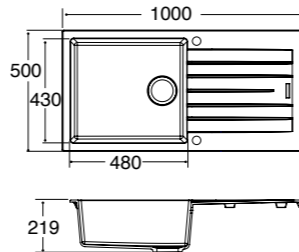

Our optional sink accessories save space and make food preparation quick and easy.

**Optional accessories**

The AKG47 glass chopping board and AKC48 stainless steel main bowl colander make preparing food quick and easy.

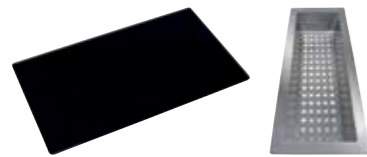
**KG74** Composite one and a half bowl sink

Anthracite



Graphite

**Features:**

- Granite/quartz construction
- Scratch resistant
- Tough and hygienic
- Super smooth metallic finish
- Reversible
- Fits in 600mm base unit
- New and exclusive strainer design

**Accessories**

- Concealed overflow
- Waste kit
- Plumbing pack

**Available in:**

- Anthracite
- Graphite

**Optional accessories:**

- Black glass chopping board, AKG47
- Stainless steel main bowl colander, AKC48
- Waste disposer, AKD01/AKD02
- Space saver plumbing pack, PP2

**Optional accessories**

The AKG47 glass chopping board and AKC48 stainless steel main bowl colander make preparing food quick and easy.

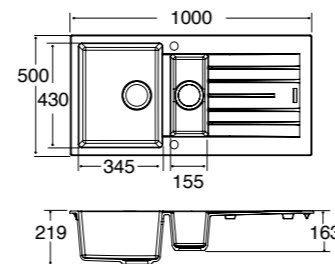
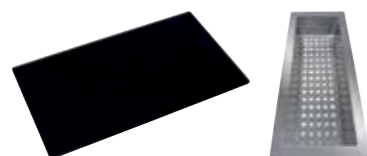
**KG81** Composite single bowl sink with stainless steel drainer bars

Anthracite



Graphite

**Features:**

- Granite/quartz construction
- Scratch resistant
- Tough and hygienic
- Super smooth metallic finish
- Reversible
- Fits in 600mm base unit
- New and exclusive strainer design
- Stainless steel drainer bars

**Accessories**

- Concealed overflow
- Waste kit
- Plumbing pack

**Available in:**

- Anthracite
- Graphite

**Optional accessories:**

- Black glass chopping board, AKG47
- Stainless steel main bowl colander, AKC48
- Waste disposer, AKD01/AKD02
- Space saver plumbing pack, PP1

**Optional accessories**

The AKG47 glass chopping board and AKC48 stainless steel main bowl colander make preparing food quick and easy.

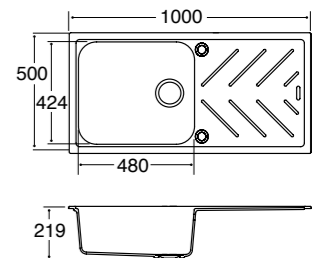
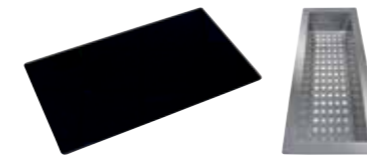
**KG82** Composite one and a half bowl sink with stainless steel drainer bars

Anthracite



Graphite

**Features:**

- Granite/quartz construction
- Scratch resistant
- Tough and hygienic
- Super smooth metallic finish
- Reversible
- Fits in 600mm base unit
- New and exclusive strainer design
- Stainless steel drainer bars

**Accessories**

- Concealed overflow
- Waste kit
- Plumbing pack

**Available in:**

- Anthracite
- Graphite

**Optional accessories:**

- Black glass chopping board, AKG47
- Stainless steel main bowl colander, AKC48
- Waste disposer, AKD01/AKD02
- Space saver plumbing pack, PP2



A built-in stainless steel trivet finishes off the design perfectly as well as offering a practical trivet for cookware.

**Optional accessories**

The AKG47 glass chopping board and AKC48 stainless steel main bowl colander make preparing food quick and easy.

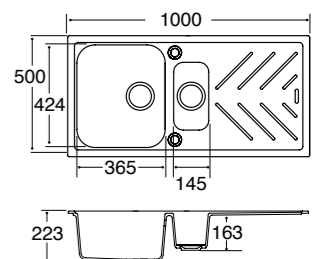
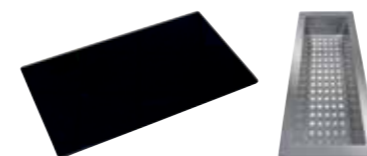

CDA's KG80 sink is the only product on the market with Ariapura technology. The composition includes titanium dioxide that actively purifies the air around your sink using natural light, transforming pollutants into harmless mineral salts. It also provides antibacterial protection, supporting the cleanliness of your home environment.

### KG80 Composite double bowl sink



#### Features

- Granite/quartz construction
- Scratch resistant
- Tough and hygienic
- Super smooth metallic finish
- Antibacterial protection for a cleaner, safer sink
- Contains titanium micro-particles to purify the air around the sink for extreme freshness
- Fits in 900mm base unit

#### Accessories

- Waste kit
- Plumbing pack

#### Optional accessories

- Pack of 2 glass chopping boards (black), AKG80BL
- Stainless steel colander, AKC80
- Strainer waste cover, AKS80

#### Available in

- Black

#### Optional accessories



Black glass chopping boards AKG80BL



Strainer waste cover, AKS80

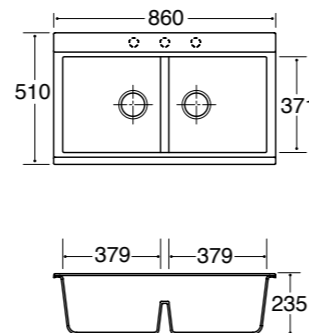

### KC10 Ceramic Belfast sink



With a weir overflow located at the side of this model and a straight sided bowl, the KC10 is a true "Belfast" sink in design. Combine with a TT56 bridge tap for definitive traditional style.

#### Features

- Classic design
- Fireclay construction
- Suitable for over or under mounting

#### Accessories

- Waste kit
- Plumbing pack

#### Optional accessories

- Space saver plumbing pack, PP1

#### Available in

- White

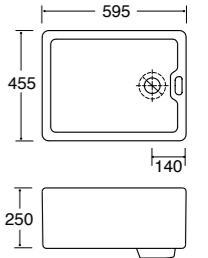

### KC11 Ceramic Belfast style sink



A handmade fireclay sink is very hard wearing. It is traditionally made, and each one will have individual characteristics. The dimensions may vary slightly and there are likely to be natural marks under the glaze giving real character.

#### Features

- Classic design
- Fireclay construction

#### Accessories

- Waste kit
- Plumbing pack

#### Optional accessories

- Space saver plumbing pack, PP1

#### Available in

- White

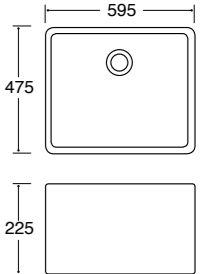

### KC12 Ceramic Belfast style double bowl sink

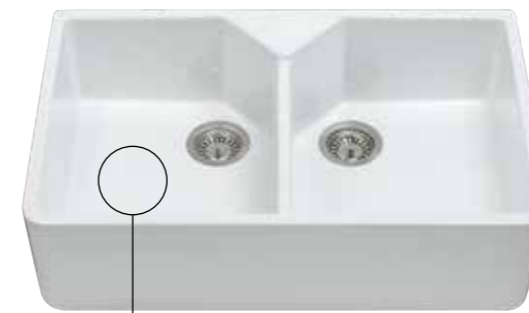

Handmade fireclay sink.

#### Features

- Classic design
- Fireclay construction

#### Accessories

- Waste kit
- Plumbing pack

#### Optional accessories

- Waste disposer and adaptor, AKD01/AKD02 and AKD03
- Space saver plumbing pack, PP2

#### Available in

- White

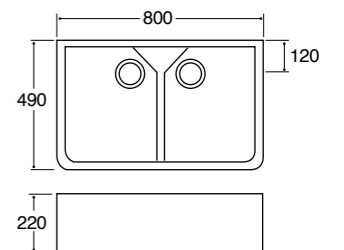

**KC23** Ceramic single bowl sink

A handmade fireclay sink is very hard wearing. It is traditionally made, and each one will have individual characteristics. The dimensions may vary slightly and there are likely to be natural marks under the glaze giving real character.

## Features

- Classic design
- Heavy duty
- Reversible
- Fits in 600mm base unit

## Accessories

- Waste kit
- Plumbing pack

## Optional accessories

- Waste disposer and adaptor, AKD01/AKD02 and AKD03
- Space saver plumbing pack, PP1

## Available in

- White

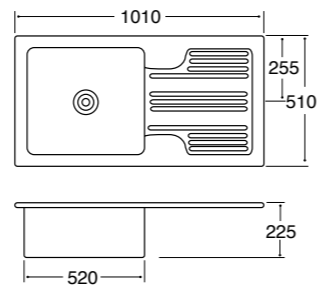
**KC73** Ceramic single bowl sink

Handmade fireclay sink.

## Features

- Classic design
- Heavy duty
- Large bowl
- Reversible
- Fits in 600mm base unit

## Accessories

- Waste kit
- Plumbing pack

## Optional accessories

- Waste disposer and adaptor, AKD01/AKD02 and AKD03
- Space saver plumbing pack, PP1

## Available in

- White

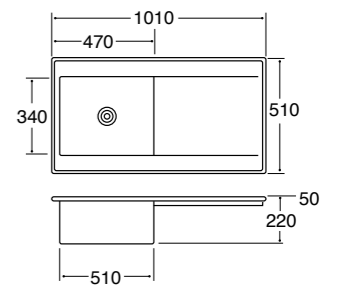
**KC24** Ceramic one and a half bowl sink

Handmade fireclay sink.

## Features

- Classic design
- Heavy duty
- Reversible
- Fits in 600mm base unit

## Accessories

- Waste kit
- Plumbing pack

## Optional accessories

- Waste disposer and adaptor, AKD01/AKD02 and AKD03
- Space saver plumbing pack, PP2

## Available in

- White

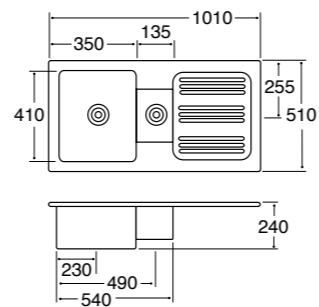
**KC74** Ceramic one and a half bowl sink

Handmade fireclay sink.

## Features

- Classic design
- Heavy duty
- Reversible
- Fits in 600mm base unit

## Accessories

- Waste kit
- Plumbing pack

## Optional accessories

- Waste disposer and adaptor, AKD01/AKD02 and AKD03
- Space saver plumbing pack, PP2

## Available in

- White

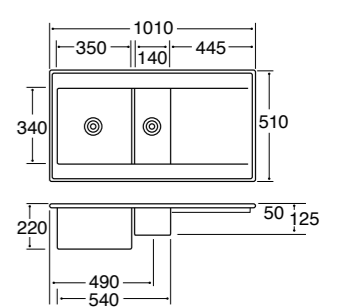



# Full undermount sinks range

CDA undermounts are available in a wide variety of sizes, styles and materials, to suit most kitchen designs.

## Stainless steel



### KCC21

- Half bowl undermount sink
  - Polished finish
  - Easy fixing system
- More details on p178



### KCC22

- Three quarter bowl undermount sink
  - Polished finish
  - Easy fixing system
- More details on p178



### KCC23

- Single bowl undermount sink
  - Polished finish
  - Easy fixing system
- More details on p178



### KCC24

- Rectangular bowl undermount sink
  - Polished finish
  - Easy fixing system
- More details on p179



### KCC27

- One and a half bowl undermount sink
  - Noise deadening pads
  - Easy fixing system
- More details on p179



### KCC28

- One and a half bowl undermount sink
  - Noise deadening pads
  - Easy fixing system
- More details on p179

## Stainless steel



### KSC21

- Half bowl undermount sink
  - Noise deadening pads
- More details on p180



### KSC22

- Three quarter bowl undermount sink
  - Noise deadening pads
- More details on p180



### KSC23

- Single bowl undermount sink
  - Noise deadening pads
- More details on p180



### KSC24

- Single bowl undermount sink
  - Noise deadening pads
- More details on p181



### KSC25

- Large single bowl undermount sink
  - Noise deadening pads
- More details on p181

## Stainless steel



### KVC30R/KVC30L

- One and a half bowl undermount sink
  - Noise deadening pads
- More details on p183



### KVC35R/KVC35L

- One and a half bowl undermount sink
  - Noise deadening pads
- More details on p183

## Composite

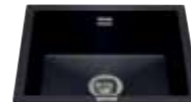

### KMG24

- Single bowl undermount/inset sink
  - Tough and hygienic
  - Granite/quartz construction
  - Available in anthracite or graphite
- More details on p184



### KMG30

- One and a half bowl undermount/inset sink
  - Tough and hygienic
  - Granite/quartz construction
  - Reversible
  - Available in anthracite or graphite
- More details on p184

## Ceramic



### KC41

- Ceramic undermount/inset half bowl sink
  - Fireclay construction
- More details on p185



### KC42

- Ceramic undermount/inset single bowl sink
  - Fireclay construction
- More details on p185

**KCC21** Stainless steel undermount half bowl sink

## Features

- Polished finish
- Easy fixing system
- Noise deadening pads

## Accessories

- Waste kit
- Plumbing pack

## Optional accessories

- Stainless steel colander, AKC04
- Waste disposer, AKD01/AKD02
- Space saver plumbing pack, PP1

## Available in

- Stainless steel

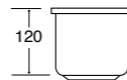
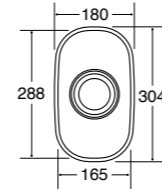
**KCC24** Stainless steel undermount rectangular single bowl sink

## Features

- Polished finish
- Easy fixing system
- Noise deadening pads

## Accessories

- Waste kit
- Plumbing pack

## Optional accessories

- Waste disposer, AKD01/AKD02
- Space saver plumbing pack, PP1

## Available in

- Stainless steel

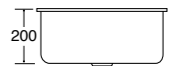
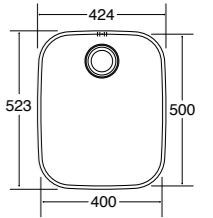
**KCC22** Stainless steel undermount three quarter bowl sink

## Features

- Polished finish
- Easy fixing system
- Noise deadening pads

## Accessories

- Waste kit
- Plumbing pack

## Optional accessories

- Waste disposer, AKD01/AKD02
- Space saver plumbing pack, PP1

## Available in

- Stainless steel

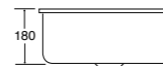
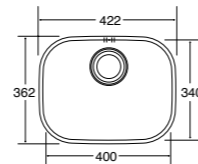
**KCC27** Stainless steel undermount right-hand one and a half bowl sink

## Features

- Polished finish
- Easy fixing system
- Noise deadening pads

## Accessories

- Waste kit
- Plumbing pack

## Optional accessories

- Waste disposer, AKD01/AKD02
- Space saver plumbing pack, PP2

## Available in

- Stainless steel

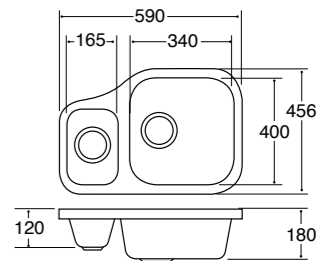
**KCC23** Stainless steel undermount single bowl sink

## Features

- Polished finish
- Easy fixing system
- Noise deadening pads

## Accessories

- Waste kit
- Plumbing pack

## Optional accessories

- Stainless steel basket, AKB10
- Waste disposer, AKD01/AKD02
- Space saver plumbing pack, PP1

## Available in

- Stainless steel

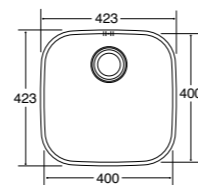
**KCC28** Stainless steel undermount left-hand one and a half bowl sink

## Features

- Polished finish
- Easy fixing system
- Noise deadening pads

## Accessories

- Waste kit
- Plumbing pack

## Optional accessories

- Waste disposer, AKD01/AKD02
- Space saver plumbing pack, PP2

## Available in

- Stainless steel

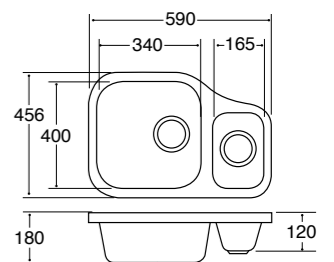

**KSC21** Stainless steel undermount half bowl sink

## Features

- 1mm heavy gauge stainless steel construction
- Noise deadening pads
- Square strainer design

## Accessories

- Concealed overflow
- Waste kit
- Plumbing pack

## Optional accessories

- Space saver plumbing pack, PP1

## Available in

- Stainless steel

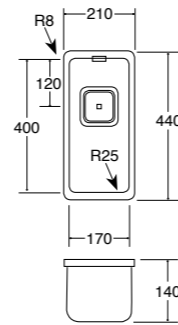
**KSC22** Stainless steel undermount three quarter bowl sink

## Features

- 1mm heavy gauge stainless steel construction
- Noise deadening pads
- Square strainer design

## Accessories

- Concealed overflow
- Waste kit
- Plumbing pack

## Optional accessories

- Space saver plumbing pack, PP1

## Available in

- Stainless steel

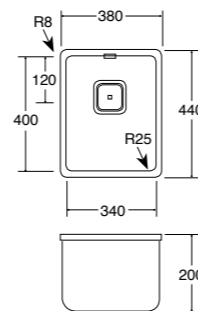
**KSC23** Stainless steel undermount single bowl sink

## Features

- 1mm heavy gauge stainless steel construction
- Noise deadening pads
- Square strainer design

## Accessories

- Concealed overflow
- Waste kit
- Plumbing pack

## Optional accessories

- Space saver plumbing pack, PP1

## Available in

- Stainless steel

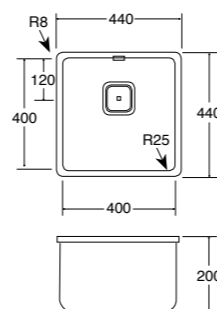
**KSC24** Stainless steel undermount single bowl sink

## Features

- 1mm heavy gauge stainless steel construction
- Noise deadening pads
- Square strainer design

## Accessories

- Concealed overflow
- Waste kit
- Plumbing pack

## Optional accessories

- Space saver plumbing pack, PP1

## Available in

- Stainless steel

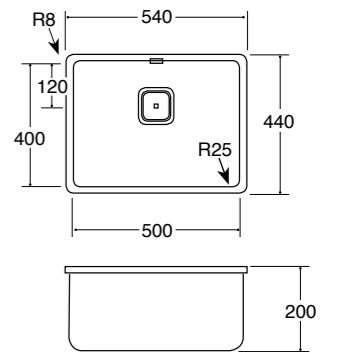
**KSC25** Stainless steel undermount large single bowl sink

## Features

- 1mm heavy gauge stainless steel construction
- Noise deadening pads
- Square strainer design

## Accessories

- Concealed overflow
- Waste kit
- Plumbing pack

## Optional accessories

- Space saver plumbing pack, PP1

## Available in

- Stainless steel

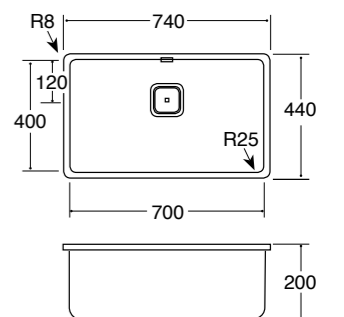

### KVC30 Stainless steel undermount one and a half bowl sink



KVC30R

#### Features:

- Satin finish
- Noise deadening pads
- New and exclusive strainer design

#### Accessories

- Concealed overflow
- Waste kit
- Plumbing pack

#### Available in:

- Stainless steel - right hand half bowl, KVC30R
- Stainless steel - left hand half bowl, KVC30L

#### Optional accessories:

- Waste disposer, AKD01/AKD02
- Space saver plumbing pack, PP2



KVC30L

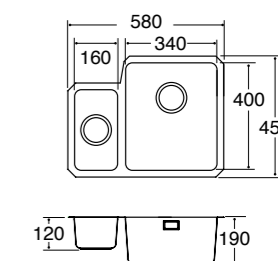

### KVC35 Stainless steel undermount one and a half bowl sink



KVC35R

#### Features:

- Satin finish
- Noise deadening pads
- New and exclusive strainer design

#### Accessories

- Concealed overflow
- Waste kit
- Plumbing pack

#### Available in:

- Stainless steel - right hand half bowl, KVC35R
- Stainless steel - left hand half bowl, KVC35L

#### Optional accessories:

- Waste disposer, AKD01/AKD02
- Space saver plumbing pack, PP2



KVC35L

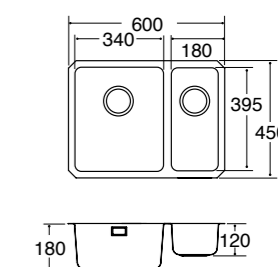

**KMG24** Composite undermount/inset single bowl sink

Anthracite



Graphite

## Features:

- Granite/quartz construction
- Tough and hygienic
- Super smooth metallic finish
- Reversible
- Fits in 600mm base unit
- New and exclusive strainer design
- Can be undermount or inset
- Both undermount and inset clips included

## Accessories

- Concealed overflow
- Waste kit
- Plumbing pack

## Available in:

- Anthracite
- Graphite

## Optional accessories:

- Waste disposer, AKD01/AKD02
- Space saver plumbing pack, PP1

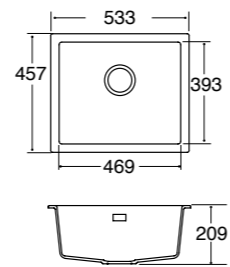
**KC41** Ceramic undermount/inset half bowl sink

A handmade fireclay sink is very hard wearing. It is traditionally made, and each one will have individual characteristics. The dimensions may vary slightly and there are likely to be natural marks under the glaze giving real character.

## Features

- Classic design
- Fireclay construction
- Can be undermount or inset

## Accessories

- Waste kit
- Plumbing pack

## Optional accessories

- Waste disposer and adaptor, AKD01/AKD02 and AKD03
- Space saver plumbing pack, PP1

## Available in

- White

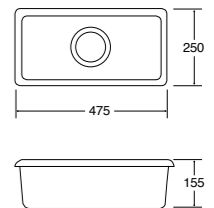
**KMG30** Composite undermount/inset one and a half bowl sink

Anthracite



Graphite

## Features:

- Granite/quartz construction
- Tough and hygienic
- Super smooth metallic finish
- Reversible
- Fits in 800mm base unit
- New and exclusive strainer design
- Can be undermount or inset
- Both undermount and inset clips included

## Accessories

- Concealed overflow
- Waste kit
- Plumbing pack

## Available in:

- Anthracite
- Graphite

## Optional accessories:

- Waste disposer, AKD01/AKD02
- Space saver plumbing pack, PP2

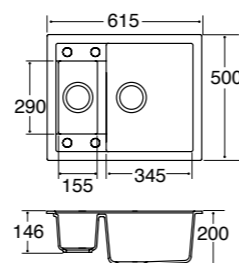

KMG30 Anthracite.

**KC42** Ceramic undermount/inset single bowl sink

Handmade fireclay sink.

## Features

- Classic design
- Fireclay construction
- Can be undermount or inset

## Accessories

- Waste kit
- Plumbing pack

## Optional accessories

- Waste disposer and adaptor, AKD01/AKD02 and AKD03
- Space saver plumbing pack, PP1

## Available in

- White

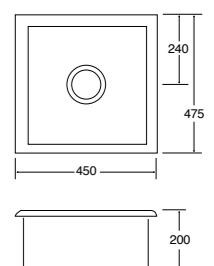

# Taps

Whether it is a simple lever tap, or something more sophisticated, choose a tap from our 2017 collection and you can be sure that it will be beautifully designed.



*Our range includes taps to suit every kitchen from minimalist styles in stainless steel, chrome or nickel to traditional mixer taps, filter and an instant hot water tap.*

## Filter tap

Our TF55 tap filters mains tap water to improve its taste, clarity and odour. Mains water is passed through a cartridge concealed under the sink and is controlled through the tap by a simple lever action.



## Professional chef style taps

A pull-out spray is a useful helping hand on some of our contemporary taps. Use the spray for thorough rinsing of fruit and vegetables, for fast defrosting, to fill large vases or buckets, or for countless other kitchen jobs.



## Hot water on demand

Speed up cooking and making hot drinks by installing a TH100 instant hot water tap. With an under-counter heating tank, this useful kitchen appliance can produce around 1.5 litres of hot water per minute, supporting many culinary tasks.



## Quick guide to taps

The range of taps from CDA covers a wide spectrum of designs, from stylish, functional taps through to cutting-edge, contemporary designer taps to make a bold statement in your kitchen.

### Flow restrictors

Where building regulations (Part G) or ECO-design requirements stipulate maximum flow rates, we offer flow reducers (ATF002/ATF003), which are designed to be fitted inside the supply tails of the tap.

### Guidance on minimum operation pressure

Taps with a minimum operating pressure of 0.4Bar, or less, are compatible with low pressure hot water systems.

Check your supply pressure before purchasing taps requiring 0.5Bar or higher.

## Contemporary taps



**TC10**  
Details on p190



**TC15**  
details on p190



**TC20**  
Details on p190



**TC65**  
Details on p192



**TC66**  
Details on p193



**TC75**  
Details on p193

## Contemporary taps



**TV7**  
Details on p199



**TV9**  
• Available in chrome or black  
Details on p199

## Pull-out taps



**TC56**  
Details on p192



**TM1**  
Details on p196



**TM30**  
Details on p197

## Contemporary taps



**TC28**  
Details on p191



**TC41**  
Details on p191



**TC55**  
• Available in chrome or nickel  
Details on p191



**TC57**  
Details on p192



**TC77**  
Details on p193



**TV5**  
Details on p198



**TV6**  
Details on p198

## Traditional taps



**TT25**  
Details on p194



**TT41**  
• Available in chrome or nickel  
Details on p194



**TT50**  
Details on p195



**TT56**  
Details on p195

## Pull-out taps



**TV11**  
Details on p200



**TV12**  
Details on p200



**TF55**  
Details on p200



**TH100**  
Details on p201

**TC10** Standard single lever tap

## Features

- Single flow
- Minimum pressure: 0.5Bar
- 360° spout rotation
- Ceramic disc valve

## Accessories

- Supplied with flexible tail pipes

## Available in

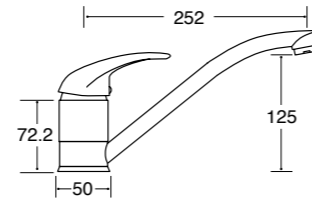

Chrome

**TC28** Contemporary quarter turn monobloc tap

## Features

- Single flow
- Minimum pressure: 0.4Bar
- Ceramic disc ¼ turn valves
- 360° spout rotation

## Accessories

- Supplied with flexible tail pipes

## Available in

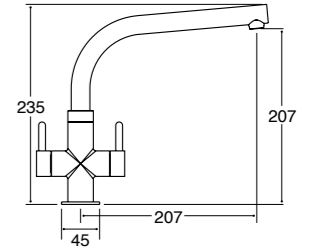

Chrome

**TC15** Classic single lever tap

## Features

- Single flow
- Minimum pressure: 0.3Bar
- WRAS approved
- Ceramic single lever valve

## Accessories

- Supplied with rigid copper tail pipes

## Available in

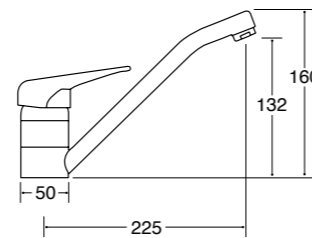

Chrome

**TC41** Quarter turn cross handle monobloc tap

## Features

- Dual flow
- Minimum pressure: 0.3Bar
- WRAS approved
- Ceramic disc ¼ turn valves

## Accessories

- Supplied with rigid copper tail pipes

## Available in

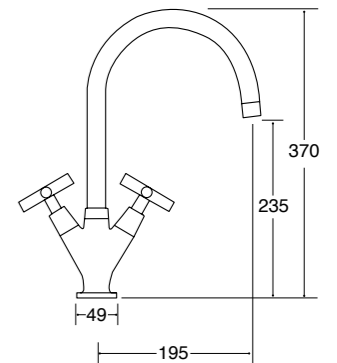

Chrome

**TC20** Standard quarter turn monobloc tap

## Features

- Single flow
- Minimum pressure: 0.1Bar
- 360° spout rotation
- Ceramic disc ¼ turn valves

## Accessories

- Supplied with flexible tail pipes

## Available in

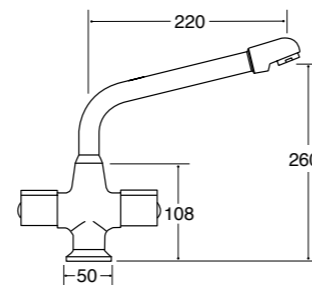

Chrome

**TC55** Monobloc tap with swan neck spout

## Features

- Dual flow
- Minimum pressure: 0.3Bar
- Ceramic disc ¼ turn valves

## Accessories

- Supplied with rigid copper tail pipes

## Available in

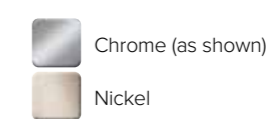

Chrome (as shown)

Nickel

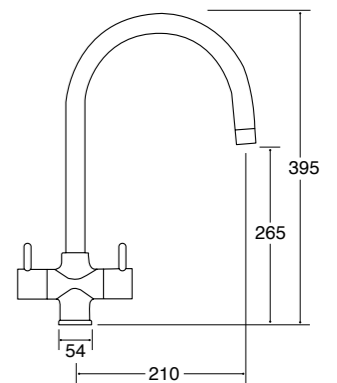



**TC56** Monobloc tap with pull-out spout

## Features

- Single flow
- Minimum pressure: 0.75Bar
- Pull-out spout
- Ceramic disc ¼ turn valves
- Hose extends up to 500mm

## Accessories

- Supplied with rigid copper tail pipes

## Available in

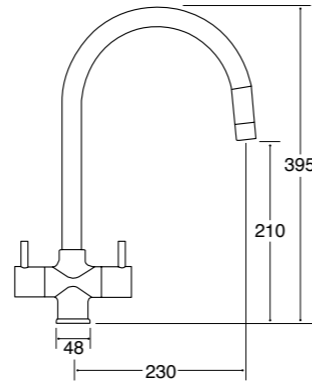

Chrome

**TC66** Side single lever tap with quad spout

## Features

- Single flow
- Minimum pressure: 0.5Bar
- Ceramic single lever valve

## Accessories

- Supplied with flexible tail pipes

## Available in

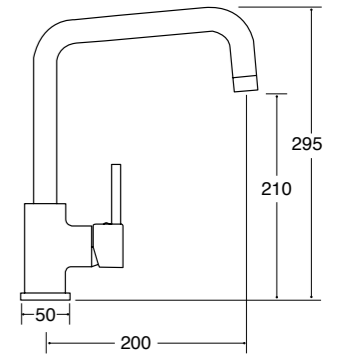

Chrome

**TC57** Side single lever tap with swan neck spout

## Features

- Single flow
- Minimum pressure: 0.5Bar
- Ceramic single lever valve

## Accessories

- Supplied with flexible tail pipes

## Available in

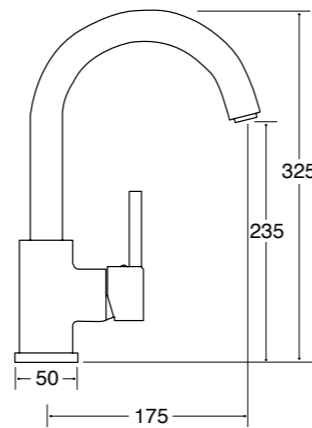

Chrome

**TC75** Contemporary single lever tap

## Features

- Single flow
- Minimum pressure: 0.4Bar
- Ceramic single lever valve

## Accessories

- Supplied with flexible tail pipes

## Available in

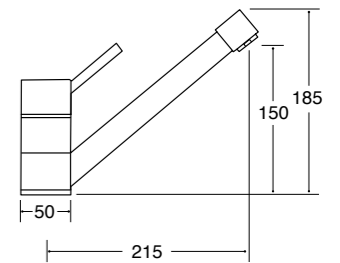

Chrome

**TC65** Monobloc tap with quad spout

## Features

- Dual flow
- Minimum pressure: 0.3Bar
- Ceramic disc ¼ turn valves

## Accessories

- Supplied with rigid copper tail pipes

## Available in

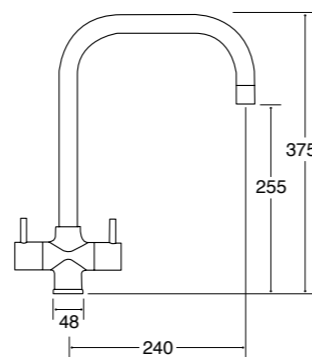

Chrome

**TC77** Contemporary slant monobloc tap

## Contemporary slanted design

The TC77 has a modern slanted design and ergonomic paddle handles for great looks and usability.

## Features

- Single flow
- Minimum pressure: 0.5Bar
- 360° spout rotation
- Ceramic disc ¼ turn valves

## Accessories

- Supplied with flexible tail pipes

## Available in



Chrome

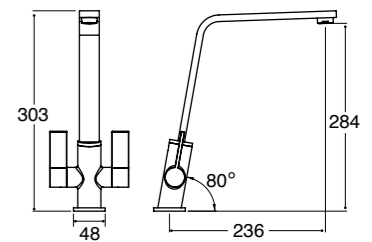

**TT25** Traditional monobloc tap



- Features**
- Dual flow
  - Minimum pressure: 0.3Bar
  - WRAS approved
  - Compression valves
- Accessories**
- Supplied with rigid copper tail pipes
- Available in**
-  Chrome

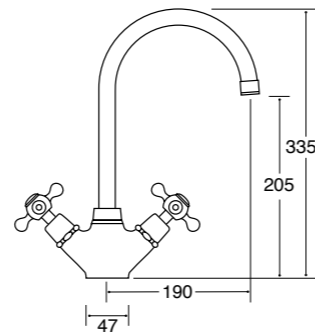

**TT50** Traditional dual lever monobloc tap



**Traditional design**  
 This traditionally designed tap with white handles looks beautiful with a Belfast sink.

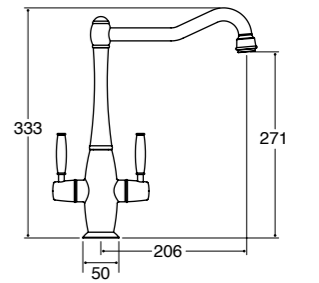

- Features**
- Single flow
  - Minimum pressure: 0.5Bar
  - 360° spout rotation
  - Ceramic disc ¼ turn valves
- Accessories**
- Supplied with flexible tail pipes
- Available in**
-  Chrome



**TT41** Traditional quarter turn lever monobloc tap



Choose white or black interchangeable handles as an optional accessory.

- Features**
- Dual flow
  - Minimum pressure: 0.2Bar
  - WRAS approved
  - Ceramic disc ¼ turn valves
- Accessories**
- Supplied with rigid copper tail pipes
- Optional accessories**
- Interchangeable handles:
    - White/chrome, ATTO1WH
    - White/nickel, ATT02WH
    - Black/chrome, ATTO1BL
    - Black/nickel, ATT02BL
- Available in**
-  Chrome (as shown)
  -  Nickel

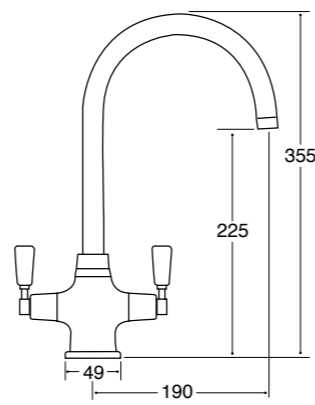

**TT56** Traditional quarter turn bridge mixer tap



Choose white or black interchangeable handles as an optional accessory.

- Features**
- Single flow
  - Minimum pressure: 0.3Bar
  - Ceramic disc ¼ turn valves
- Accessories**
- Supplied with adjustable inlet pipes
- Optional accessories**
- Interchangeable handles:
    - White/chrome, ATTO1WH
    - Black/chrome, ATTO1BL
- Available in**
-  Chrome

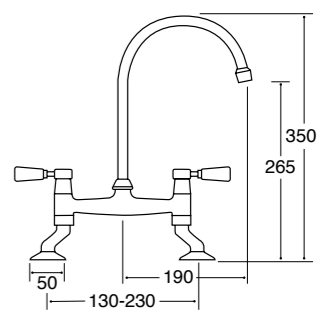

**Co-ordinating products**  
 This tap is ideal for installation with a Belfast style sink.

**TM1** Contemporary single lever tap with pull-out spray

## Features

- Single flow
- Minimum pressure: 1Bar
- Pull-out spray
- Ceramic disc valve

## Accessories

- Supplied with flexible tail pipes

## Available in



Chrome

## Fitting note

- Please ensure that your supply pressure is adequate.

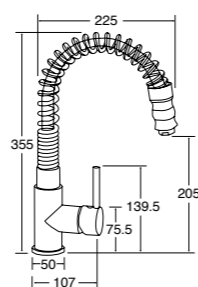
**TM30** Single lever professional style coil tap with pull-out spray

## Features

- Solid stainless steel construction
- Single flow
- Minimum pressure: 1Bar
- Pull-out spray
- 360° spout rotation
- Ceramic disc single lever valve

## Accessories

- Supplied with flexible tail pipes

## Available in



Stainless steel

## Fitting note

- Please ensure that your supply pressure is adequate.

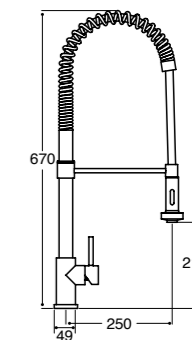

**Professional style**  
This professional coil tap with pull-out spray is perfect for rinsing food, filling large pans and making your sink a flexible work space.

**TV5** Contemporary side single lever tap



- Features
- Single flow
  - Minimum pressure: 0.5Bar
  - 360° spout rotation
  - Ceramic disc single lever valve

- Accessories
- Supplied with flexible tail pipes

Available in

 Chrome

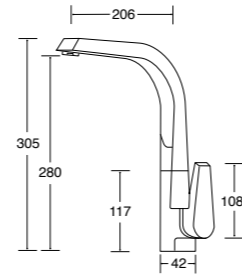

**TV7** Contemporary side single lever tap with swivel spout



- Features
- Single flow
  - Minimum pressure: 0.75Bar
  - 360° spout rotation
  - Swivel aerator for precise flow control
  - Ceramic disc single lever valve

- Accessories
- Supplied with flexible tail pipes

Available in

 Chrome



Swivel spout for precise flow control

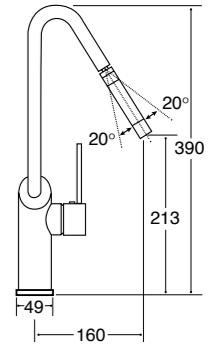

**TV6** Round tower single lever tap



- Features
- Single flow
  - Minimum pressure: 0.5Bar
  - 360° spout rotation
  - Ceramic disc single lever valve

- Accessories
- Supplied with flexible tail pipes

Available in

 Chrome

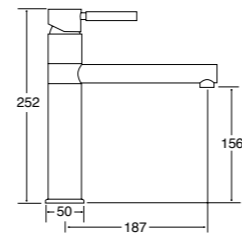

**TV9** Contemporary square side single lever tap



Chrome





Matt black

- Features
- Single flow
  - WRAS approved
  - Minimum pressure: 0.5Bar
  - 360° spout rotation
  - Ceramic disc single lever valve

- Accessories
- Supplied with flexible tail pipes

Available in

 Chrome

 Matt black

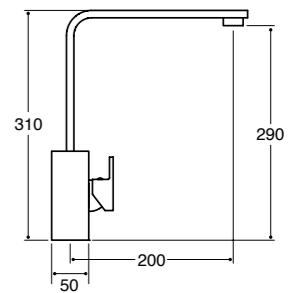

**TV11** Single lever tap with black pull-out spray



Features

- Solid stainless steel construction
- Single flow
- Minimum pressure: 1.5Bar
- Pull-out spray
- 360° spout rotation
- Ceramic disc valve

Accessories

- Supplied with flexible tail pipes

Available in



Fitting note

- Please ensure that your supply pressure is adequate.

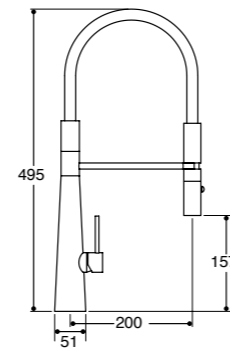

**TF55** Monobloc filter tap with swan neck spout

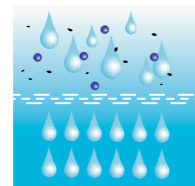

Filters the water

Features

- Dual flow
- Minimum pressure: 0.4Bar
- 2 way ceramic disc valve
- WRAS approved

Accessories

- Filter and installation kit
- Supplied with rigid copper tail pipes

Optional accessories

- Replacement filter, ATF001

Available in



Fitting note

- We recommend that you replace the filter every six months.

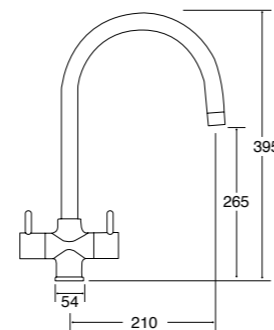

**TV12** Slimline single lever tap with pull-out spray



Features

- Single flow
- Minimum pressure: 1.3Bar
- Pull-out spray
- Ceramic disc ¼ turn valves
- 360° spout rotation
- Ceramic disc valve

Accessories

- Supplied with flexible tail pipes

Available in

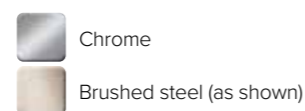

Fitting note

- Please ensure that your supply pressure is adequate.

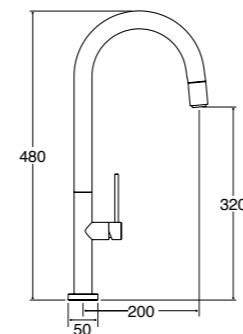

**TH100** 3-in-1 instant hot water tap



Standard hot and cold supply

Push lever back for hot 98°C water

Features

- Non-pressurised tank for increased reliability
- Electronic display on tank
- Minimum pressure: 1Bar
- 170° spout rotation
- 2.4L tank
- Filter included
- 1.4 - 1.9L/min flow rate
- Dispenses 1.25L before the temperature drops
- Rapid 7-8 minutes initial heat up from cold supply
- Unique heating system, allows several cups of 98°C water to be dispensed

Accessories

- Supplied with flexible tail pipes

Available in



Fitting note

- Please ensure that your supply pressure is adequate.
- The filter must be replaced every 6 months to prevent limescale build-up.



WRAS approved



Under counter heating tank

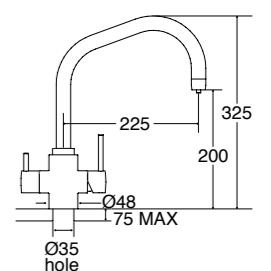

## Oven accessories

### Catalytic liner kits

Code	Contents	Compatible with
C3OL	2 side panels and 1 back panel	RC9322 <sup>1</sup> , RV1061 <sup>1</sup> , RV1002 <sup>1</sup>
C5OL	2 side panels and 1 back panel	RV701 <sup>1</sup> , RV1200 <sup>2</sup>
C6OL	2 side panels	RV701 <sup>3</sup> , RV1200 <sup>3</sup> , DK751 <sup>3</sup> , DK951 <sup>3</sup> , 9Q6 <sup>3</sup>
C7OL	2 side panels and 1 back panel	DK751 <sup>1</sup>
C9OL	2 side panels and 1 back panel	SK381
C10OL	2 side panels and 1 back panel	6Q5, 9Q6 <sup>1</sup> , DK1151, DK951 <sup>1</sup>
C12OL	2 side panels and 1 back panel	SK451



C13OL

### Telescopic shelf kits

Code	Contents	Compatible with
TSK3	3 shelves and side rails 6 height positions	SK110, SK210, SK310, SK410



TSK3

Recommended by CDA

When you're busy making your magic in the kitchen, that's when accidents can happen. Reduce this risk by having a professional shelving system on your oven.

Our telescopic shelf kits allow dishes to slide forward and back with ease and importantly have the strength to hold the heaviest roast.



<sup>1</sup> main oven only. <sup>2</sup> main and second ovens only. <sup>3</sup> top oven only.

Please check product pages for compatibility.

## Extractor accessories

### AED51 125mm x 1m flexible ducting kit

- White wall outlet
- 2 cable ties
- 1m flexible hose
- Fixing kit



### AED53 125mm x 6m flexible ducting kit

- White wall outlet
- 2 cable ties
- 6m flexible hose
- Fixing kit



### AED54 125mm x 3m rigid ducting kit

- White wall outlet
- 2 x 1m rigid ducting
- 500mm rigid ducting
- Wall plate
- Connector
- 125mm elbow bend
- 2 threaded hose connectors
- 1m flexible hose
- Horizontal bend
- Fixing kit



### AED61 150mm x 1m flexible ducting kit

- White wall outlet
- 2 cable ties
- 1m flexible hose
- Fixing kit

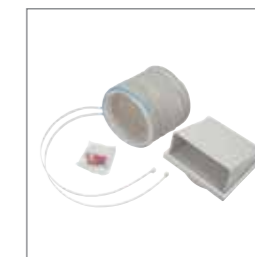

### AED63 150mm x 6m flexible ducting kit

- White wall outlet
- 2 cable ties
- 6m flexible hose
- Fixing kit























### AED64 150mm x 3m rigid ducting kit







- White wall outlet
- 2 x 1m rigid ducting
- 350mm rigid round ducting
- Wall plate
- Connector
- 125mm elbow bend
- 2 threaded hose connectors
- 1m flexible hose
- Horizontal bend
- Round to rectangular adaptor
- Fixing kit



## Extractor accessories

 <b>CHA1</b> charcoal filter (pack of 1) CTE6, CCA5	 <b>CHA2</b> charcoal filter (pack of 2) EVC4, EVCK4, EVM9, EVPC9	 <b>CHA4</b> charcoal filter (pack of 1) ECH6/71/91/101	 <b>CHA5</b> charcoal filter (pack of 1) CST61
 <b>CHA11</b> charcoal filter (pack of 2) EDD91	 <b>CHA12</b> charcoal filter (pack of 1) ECN62/72/92, ECP62/72/82/92/102/112	 <b>CHA14</b> charcoal filter (pack of 2) 3D9	 <b>CHA15</b> charcoal filter (pack of 1) EIN60, EVA60/70/90, ECA60
 <b>CHA16</b> charcoal filter (pack of 2) EVQ7	 <b>CHA17</b> charcoal filter (pack of 2) EKP60/70/90	 <b>CHA18</b> charcoal filter (pack of 2) EVX101	 <b>CHA19</b> charcoal filter (pack of 2) EDD61
 <b>CHA21</b> charcoal filter (pack of 2) CCA7, EVG6/9, EVP61/91/101/121, EVPK90	 <b>CHA24</b> charcoal filter (pack of 2) ECH6/71/91/101	 <b>CHA25</b> charcoal filter (pack of 2) ECHK90, ECPK90	 <b>CHA30</b> charcoal filter (pack of 2) 3S10
 <b>CHA32</b> charcoal filter (pack of 2) 3U10	 <b>GRE1</b> acrylic grease filter CCA5, EIN60	 <b>GRE2M</b> metal grease filter CCA5	 <b>GRE3M</b> metal grease filter EIN60
 <b>AEV01SS</b> chimney section EVM9			

## Refrigeration and dishwasher accessories

 <b>ABC001</b> keg connector (G-type) BVB4	 <b>ABC002</b> CO2 bottle BVB4	 <b>ABC003</b> cleaning tablets BVB4	 <b>ABC004</b> cleaning connector (G-type) BVB4
 <b>ABC005</b> keg connector (A-type) BVB4	 <b>ABC006</b> cleaning connector BVB4		

### AFJ61 Joining kit

The AFJ61 joining kit contains a steel frame, plinths and joining strips to seamlessly combine the FF820, FWC860 and FF880 appliances to make the ultimate cooling station.



### Wine cooler glass shelves

Code	Contents	Compatible with
AFG31	Glass shelves (pack of 3)	FWC303, FWC623
AFG61	Glass shelves (pack of 3)	FWC603, FWC860

Our wine cooler glass shelves are perfect for storing smaller items such as bottles and cans.













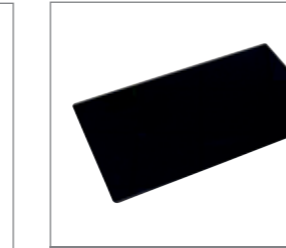
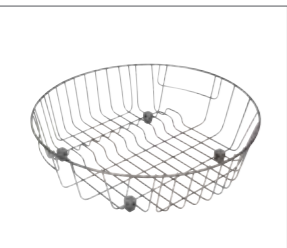

AFG31

### Dishwasher wine glass holder

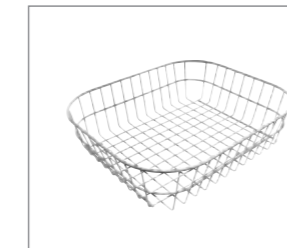
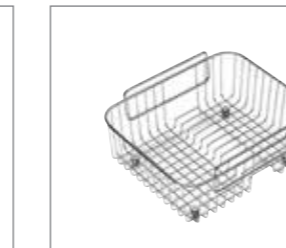
Code	Contents	Compatible with
AWG100	Variospace wine glass holder	WC600, WF610

## Sink accessories

 <b>AKW03</b> wooden chopping board KA71	 <b>AKW05</b> wooden chopping board KR21	 <b>AKW20</b> wooden chopping board KA20, KA21, KA22	 <b>AKW38</b> wooden chopping board KA30, KA32, KA80, KA82
 <b>AKW57</b> wooden chopping board KA55, KA50, KA52, KA72	 <b>TRE</b> wooden chopping board CCP3	 <b>AKG80BL</b> black glass chopping boards KG80	 <b>AKG47</b> black glass chopping board KG43, KG44, KG73, KG74, KG81, KG82
 <b>AKB05</b> basket KR21	 <b>AKB10</b> basket KCC23	 <b>AKB38</b> basket KA32, KA80, KA82	 <b>AKB57</b> basket KA55, KA50, KA52, KA72
 <b>AKC04</b> colander KCC21	 <b>AKC12</b> colander KVL01, KVL02, KVF21, KVF22	 <b>AKC80</b> colander KG80	 <b>AKC48</b> colander KG43, KG44, KG73, KG74, KG81, KG82

## Sink accessories

### Sink accessory packs

Code	Contents	Compatible with
PA1	Wooden chopping board and stainless steel basket	AS1
PA2	Wooden chopping board and stainless steel baskets	AS2

Maximise your kitchen workstation with our sink accessory packs. Increase work space with a chopping board and keep your sink bowl looking new with a matching sink basket.



PA1



PA2



### Plumbing packs

Code	Contents	Compatible with
PP1	Space saver plumbing pack	All single bowl sinks
PP2	Space saver plumbing pack	All one and a half bowl sinks

### Waste covers

Code	Contents	Compatible with
AKS80	Circular waste cover	KG80



## Sink accessories

### Waste disposers

Code	Contents	Compatible with
AKD01	380W waste disposer	All sinks except KSC models and KC10
AKD02	550W waste disposer	All sinks except KSC models and KC10
AKD03	Waste disposer adaptor	All ceramic sinks using AKD01 or AKD02

- Easy to install
- Convenient
- Clean and hygienic
- Time saving
- Smell free
- Mess free
- Needs no regular maintenance
- Cheap to run



AKD01



AKD02



AKD03

## Splashbacks

### Square metal splashbacks

Size	Stainless steel	Black
600W x 750H	CSB6SS	CSB6BL
700W x 750H	CSB7SS	CSB7BL
900W x 750H	CSB9SS	CSB9BL
1000W x 750H	CSB10SS	CSB10BL
1200W x 750H	CSB12SS	CSB12BL



Stainless steel

### Square glass splashbacks

Size	Black	Grey
600W x 750H*	ASG6BL	ASG6GR
700W x 750H*	ASG7BL	ASG7GR
900W x 750H*	ASG9BL	ASG9GR
1000W x 750H*	ASG10BL	ASG10GR
1200W x 750H*	ASG12BL	ASG12GR



Black

## Heating accessories

### APH01SS Plinth heater

- Stainless steel finish
- 3 heat settings: cold (fan only), warm, hot
- On-off switch with neon indicator
- Automatic safety cut out
- Rated electrical power: 2kW
- Power supply required: 13A

Our 2kW slimline plinth heater provides instant heat where space is at a premium and discreet yet effective heating is required.

Cleverly concealed in the 'kick space' beneath kitchen units, stairwells and fitted furniture, a plinth heater eliminates the need for a separate radiator, allowing better use of the kitchen space.

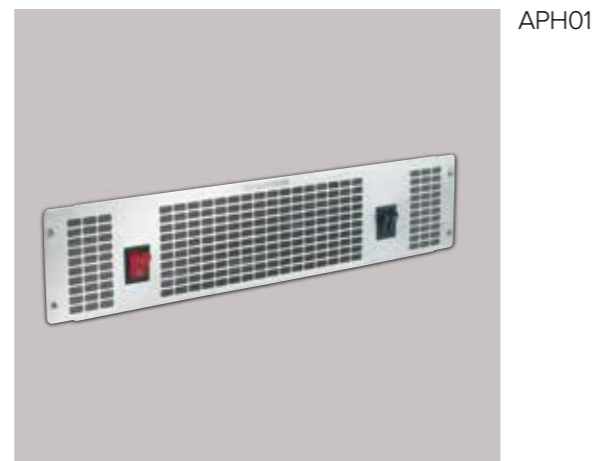

APH01

### Curved glass splashbacks

Size	Black	Grey	Compatible with
600W x 750H*	ASG62CBL	ASG62CGR	ECP62/72/82, EKP60/70/90
700W x 750H*	ASG72CBL	ASG72CGR	ECP62/72/82, EKP60/70/90
800W x 750H*	ASG82CBL	ASG82CGR	ECP62/72/82
900W x 750H*	ASG92CBL	ASG92CGR	ECP92/102/112
900W x 750H*	ASG92KBL	ASG92KGR	EKP90
1000W x 750H*	ASG102CBL	ASG102CGR	ECP92/102/112
1100W x 750H*	ASG112CBL	ASG112CGR	ECP92/102/112



Grey

\*Our toughened glass splashbacks are handmade, so dimensions shown may vary by up to 5mm.

# Accessories

## Tap accessories

Product	Code	Compatible with
Ceramic filter	ATF001	TF55
Black tap handles	ATT01BL	TT41CH, TT56CH
White tap handles	ATT01WH	TT41CH, TT56CH
Black tap handles	ATT02BL	TT41NI
White tap handles	ATT02WH	TT41NI
Flow rate restrictors*	ATF002	All taps with rigid copper tail pipes
Flow rate restrictors*	ATF003	All taps with flexible tail pipes

\*Provides 'Part G' compliance.



TT41 tap handles



TT56 tap handles

## Website

You'll find the latest news and product information at [www.cda.eu](http://www.cda.eu).

You can also locate your nearest CDA retailer, register your purchase or contact our customer care team.

From time to time our products are changed, specifications updated and new products launched. Visit our website for all up to date information and specifications.

[www.cda.eu](http://www.cda.eu)



## Guarantee

### Terms and conditions of guarantee

- Parts are defined as mechanical/electrical parts only.
- Products registered outside of the 30 day period will receive 12 months parts and labour.
- Proof of date of purchase must be supplied.
- To qualify for free parts they must be fitted by a CDA appointed engineer.
- Any attempts to modify or repair an appliance by an unauthorised person will render all guarantees invalid.
- A charge will be made for attending a reported fault that transpires to be due to misuse or mis-installation.
- CDA retains the right to invalidate the guarantee in the event of physical or verbal abuse towards any member of staff.
- CDA guarantees cover domestic use only - commercial use is not covered.
- Guarantees in whole or part are not transferable.
- Taps – During the first year, at our discretion we may pay for refitting (on receipt of the faulty part/tap, once inspected and deemed faulty) up to a maximum defined cost.
- The provision of services under the guarantee neither extends the term of the guarantee nor sets in motion a new guarantee period. The guarantee period for spare parts fitted ends with the expiry of the guarantee on the appliance as a whole. The guarantee remains effective from the date of purchase.
- On the occasion that a product is over 2 years old and is considered to be beyond repair, or uneconomical to repair, then we will offer a replacement appliance and charge an appropriate monetary offset in respect of the period of use already enjoyed.
- Guarantees apply in the UK and Southern Ireland only.

### What is not covered

- Transport damage for which CDA is not responsible.
- Improper installation and assembly.
- Improper use including where an appliance has been used in a non-domestic environment, or poor maintenance, or failure to observe the operating instructions.
- Faults due to accidental damage or misuse.
- Damage caused by the appliance coming into contact with unsuitable materials.
- Claims in respect of compensation for consequential loss, except where such liability is legally mandatory.
- Consumables and cosmetic parts such as glass, bulbs, seals, fuses, filters, external hoses, cosmetic parts, baskets, trays, burner caps, burner bases etc.
- Damage to, or during, the replacement of any light bulbs or removable parts of glass and plastic.
- Gas leaks not related to a CDA appliance.
- TH100 3-in-1 instant hot water tap is guaranteed for 2 year parts and 2 year labour.

Details of extended warranties are available on request.

This table shows where the guarantee is restricted due to non-domestic conditions:

	5 year parts, 2 year labour	2 year parts, 2 year labour	1 year parts, 1 year labour
Normal domestic sale and use	✓		
Rental or service apartment (non-students)		✓	
Students (communal living and non-communal) not new build		✓	
Students (communal living and non-communal) new build		✓	
Students (non-communal) one student per kitchen	✓		
Semi-commercial e.g. school domestic science lab			✓

E & O E • ALL DIMENSIONS AND ILLUSTRATIONS ARE PROVIDED FOR GUIDANCE ONLY. CDA RESERVE THE RIGHT TO CHANGE SPECIFICATIONS WITHOUT PRIOR NOTICE.

WEEE PRODUCER REGISTRATION NUMBER: WEE/FD0074UR.

## Oven symbols



Oven light

---



Defrost

---



Conventional oven

---



Fan assisted oven

---



Fan oven

---



Fan cooking with lower heat

---



Fan cooking with upper heat

---



Fan with lower heat

---



Browning oven

---



Warming oven

---



Grill/Half grill

---



Turbo grill

---



Fanned electric grill/Half fanned electric grill

---



Rotisserie electric

---



Rotisserie fanned grill

---



Rotisserie conventional

---



Steam oven

---



Clean function

---



Pyrolytic cleaning

---



Gas oven

---



Fanned gas oven

---



Rotisserie gas

---



Microwave/Microwave and grill function

---



Microwave and fan oven

---



For more information please contact:

The Sales Department on **01949 862010**

The Customer Care Department on **01949 862012**

[www.cda.eu](http://www.cda.eu)

**The CDA Group Ltd.** Harby Road, Langar, Nottinghamshire, NG13 9HY T: **01949 862 000** F: **01949 862 001** E: [sales@cda.eu](mailto:sales@cda.eu)

Distributed in Ireland by: **Bodel Distributors**, Hulls Lane, Lisburn, BT28 2SR T: **048 9267 2412** F: **048 9267 1873** W: [www.bodel.com](http://www.bodel.com)

Distributed in Pakistan by: **Chughtaiz**, Lahore, Pakistan T: **+92 42 3578 2891 2** W: [www.chughtaiz.com](http://www.chughtaiz.com)